















Marea - Marea Weekend Introduction and technical data

99 range

Index

00.

	page		page
INTRODUCTION		CLUTCH	43
- Identification data	1	GEARBOX AND DIFFERENTIAL	44
- Weights	3	BRAKES	48
- Performance - Fuel consumption	4	STEERING	50
- Dimensions	6	WHEELS - WHEEL GEOMETRY	51
- Capacities	8	FRONT SUSPENSION	53
- Specifications of Fiat Lubricant product	11	REAR SUSPENSION	55
 		ELECTRICAL EQUIPMENT	57
TECHNICAL DATA		- Starting	58
Engine  16v  20v		- Recharging	60
- Specifications	12	- Electronic injection/ignition	61
- Typical curves	13	 	
- Cylinder block/crankcase and associated components	14	SPECIAL TOOLS  16v	63
- Cylinder head and valve gear components	18	TIGHTENING TORQUES	65
- Counter-balance shaft	22		
- Lubrication	23		
- Cooling system	24		
- Fuel system	25		
Engine  JTD  JTD			
- Technical data	26		
- Typical curves	27		
- Cylinder block/crankcase and associated components	28		
- Cylinder head and valve gear components	32		
- Counter-balance shafts	36		
- Lubrication	37		
- Cooling system - fuel system	39		
- Fuel system	40		
- Supercharging	42		

	CHASSIS	ENGINE	VERSION	MAREA	MAREA WEEKEND	GEARBOX	
							
	ZFA 185 000	182 B2.000	185 AX P1A 17	●		●	
			185 BX P1A 18		●		
		182 A4.000	185 AX B1A 01	●		●	
			185 AX B1A 01B (▲)	●			
			185 AX B1A 01C (■)	●			
			185 BX B1A 05		●		
			185 BX B1A 05B (▲)		●		
			185 BX B1A 05C (■)		●		
			185 AX B11 08	●			
185 BX B11 12			●				
		182 A2.000	185 AX C1A 02	●		●	
			185 AX C1A 02B (▲)	●			
			185 AX C1A 02C (■)	●			
			185 BX C1A 06		●		
	185 BX C1A 06B (▲)			●			
185 CX C1A 06C (■)		●					
	182 B7.000	185 AX M1A 19	●		●		
		185 AX M1A 19B (■)	●				
		185 BX M1A 20		●			
		185 BX M1A 20B (■)		●			
	182 A8.000	185 AX F1A 10	●		●		
		185 AX F1A 14		●			
	182 B4.000	185 AX N1A 21	●		●		
		185 BX N1A 22		●			
	185 A6.000	185 AX Q1A 23	●		●		
		185 BX Q1A 24		●			

(▲) Versions for specific markets (France)

(■) Voluntary for Germany

Introduction

Identification data

Marea- Marea Weekend

98 range

00.0

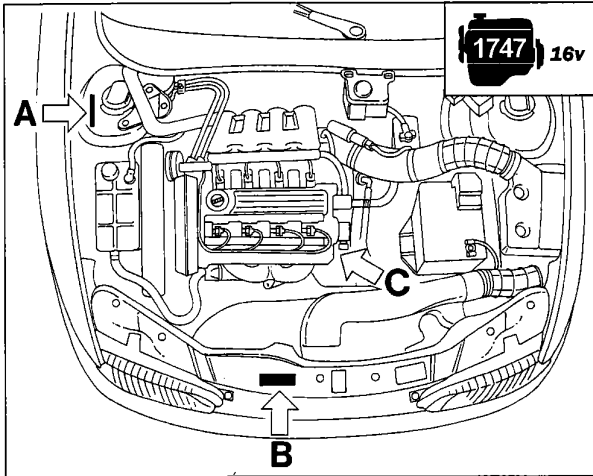

P4F003A01

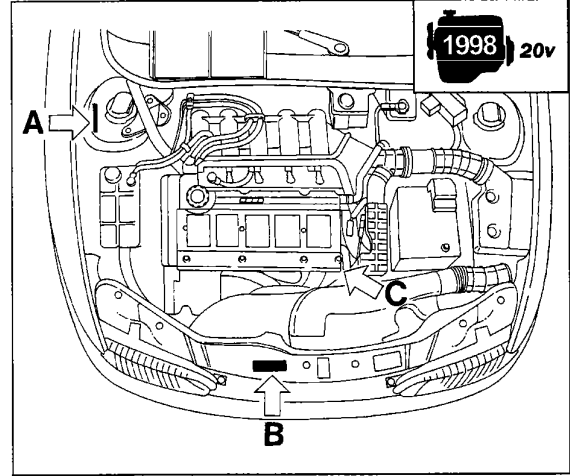

P4F003A02

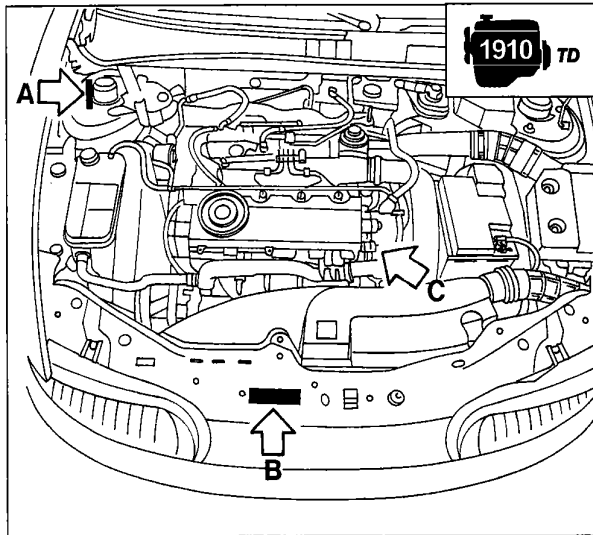

P4F003A03

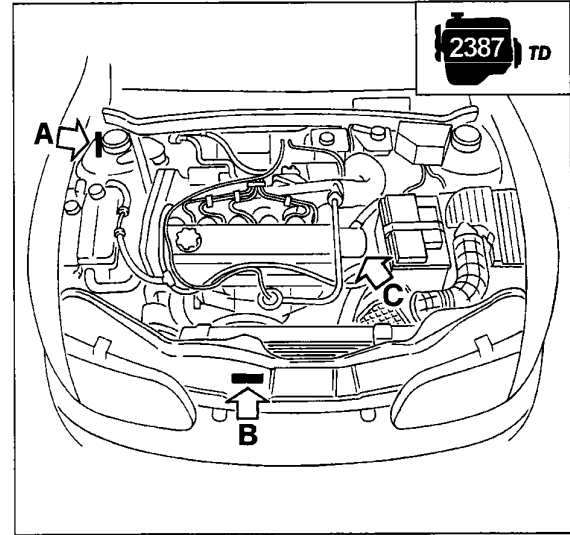



















P4F003A04

- A. Vehicle type identification code and chassis number
- B. V.I.N. Plate (EEC regulations)
- C. Engine type and number

- A. Name of manufacturer
- B. Homologation number
- C. Vehicle type identification code
- D. Chassis manufacture number
- E. Maximum authorized weight of vehicle fully laden
- F. Maximum authorized weight of vehicle fully laden plus trailer
- G. Maximum authorized weight on first axle (front)
- H. Maximum authorized weight on second axle (rear)
- I. Engine type
- L. Bodywork version code
- M. Spares number
- N. Correct value of smoke absorption coefficient (for Diesel engines only)

FIAT	A	
	B	
	C	D
	E	kg
	F	kg
	1-	G kg
	2-	H kg
	N	MOTORE - ENGINE
	VERSIONE - VERSION	L
	N° PER RICAMBI N° FOR SPARES	M

P3F003A01

ENGINE TYPE		 16v	 16v	 16v	 20v	 TD 75	 JTD	 JTD
	Marea	1085	1140 1165 (▼)	1195	1255	1185	1215	1295
	Marea Weekend	1145	1200 1225 (▼)	1255	1315	1245	1275	1355
	Marea +590= (575)*    *	1675	1730 1755 (▼)	1785	1830	1775	1805	1870
	Marea Weekend +595= (580)**    **	1740	1795 1820 (▼)	1850	1895	1840	1870	1950
Permissible loads on the axles ■		1000	1000	1000	1000	1000	1000	1000
		1000	1000	1000	1000	1000	1000	1000
Maximum permissible load on the roof		80	80	80	80	80	80	80
Load on the tow hook (trailer with braking system)		70	70	70	70	70	70	70
	Without braking system	400	400	400	400	400	400	400
	With braking system	1200	1200	1200 (1300)●	1300 (1400)●	1300	1300	1400

- Loads which must never be exceeded
- (*) Specific figures for 1998 20v and 2387 JTD versions
- (**) Specific figures for 1998 20v version
- (●) Specific figures for the Marea Weekend
- (▼) Specific figures for the 1581 16v c.a. version

NOTE FOR VERSIONS WITH ACCESSORIES: In the presence of special equipment (non standard air conditioning, sun roof, trailer towing device, etc.), the empty weight increases and therefore the carrying capacity may decrease in relation to the maximum permissible loads.





Introduction









Marea - Marea Weekend

Performance - Fuel consumption

99 range

00.0

ENGINE TYPE	 1242 16v	 1581 16v	 1581 16v C.A.	 1747 16v	 1993 20v
-------------	---	---	--	---	---

 <p>Speed km/h (average load)</p>		41	46	MAX 187 (185)*	49	59	
		74	80		85	94	
		108	124		125	139	
		142	173		164	182	
		172 (171)*	187 (185)*		195 (193)*	210 (208)*	
		41	46		49	54	
(*) For Marea Weekend version							
 <p>Max. climable gradient fully laden</p>	<i>Marea</i>	34	36	32	38	39	
	<i>Marea Weekend</i>	31	33	30	35	36	
 <p>Fuel consumption in accordance with directive 93/116/CE (litres/100 km)</p>	Urban	<i>Marea</i>	9.8	11.3	13.8	11.5 (11.2)●	14.2
		<i>Marea Weekend</i>	10	11.5	14.1	11.8 (11.5)●	14.3
	Extra-urban	<i>Marea</i>	5.6	6.6 (6.5)●	8.3	6.6 (6.3)●	7.3
		<i>Marea Weekend</i>	5.8	6.6 (6.5)●	8.5	6.8 (6.5)●	7.4
	Combined	<i>Marea</i>	7.2	8.3 (8.2)●	10.3	8.4 (8.1)●	9.8
		<i>Marea Weekend</i>	7.3	8.4 (8.3)●	10.6	8.6 (8.3)●	9.9
CO ₂ exhaust emissions (g/km)	<i>Marea</i>	170	197 (195)●	246	199 (192)●	234	
	<i>Marea Weekend</i>	173	200 (198)●	251	205 (198)●	237	













The fuel consumption figures in accordance with directive 93/116/CE have been defined during the course of homologation tests which include:

- an urban cycle which includes a cold start followed by a simulated urban cycle.
- an extra-urban cycle which includes frequent acceleration in all gears simulating normal out of town usage of the vehicle. The speed varies between 0 and 120 km/h.
- the average combined consumption includes 37% of the urban cycle and 63% of the extra-urban cycle.

The type of route, traffic conditions, driving style, weather conditions, trim level/equipment/accessories, presence of special equipment and the state of the vehicle in general can lead to different fuel consumption figures from those established using the above mentioned procedures.

The CO₂ exhaust emissions (in g/km) are measured during the average combined cycle.

(☆) Versions for specific markets (France)

		ENGINE TYPE	 TD 75	 JTD	 JTD
Speed km/h (average load) 			36	36	36
			62	52	62
			96	97	101
			135	136	141
			167 (165)*	185 (183)*	197 (195)*
			36	36	39
(*) For Marea Weekend					
	Max. clima- ble gradient fully laden %	Marea	37	40	41
		Marea Weekend	34	37	38
	Urban	Marea	8.5	7.4	9.0
		Marea Weekend	8.7	7.5	9.1
	Extra-urban	Marea	5.1	4.6	5.6
		Marea Weekend	5.3	4.7	5.7
	Combined	Marea	6.4	5.6	6.7
		Marea Weekend	6.5	5.7	6.8
Fuel consumption figures in ac- cordance with directive 93/116/CE (litres/100 km)					
CO ₂ exhaust emissions (g/km)		Marea	169	149	177
		Marea Weekend	173	151	180

Introduction

Dimensions

Marea

98 range

00.o

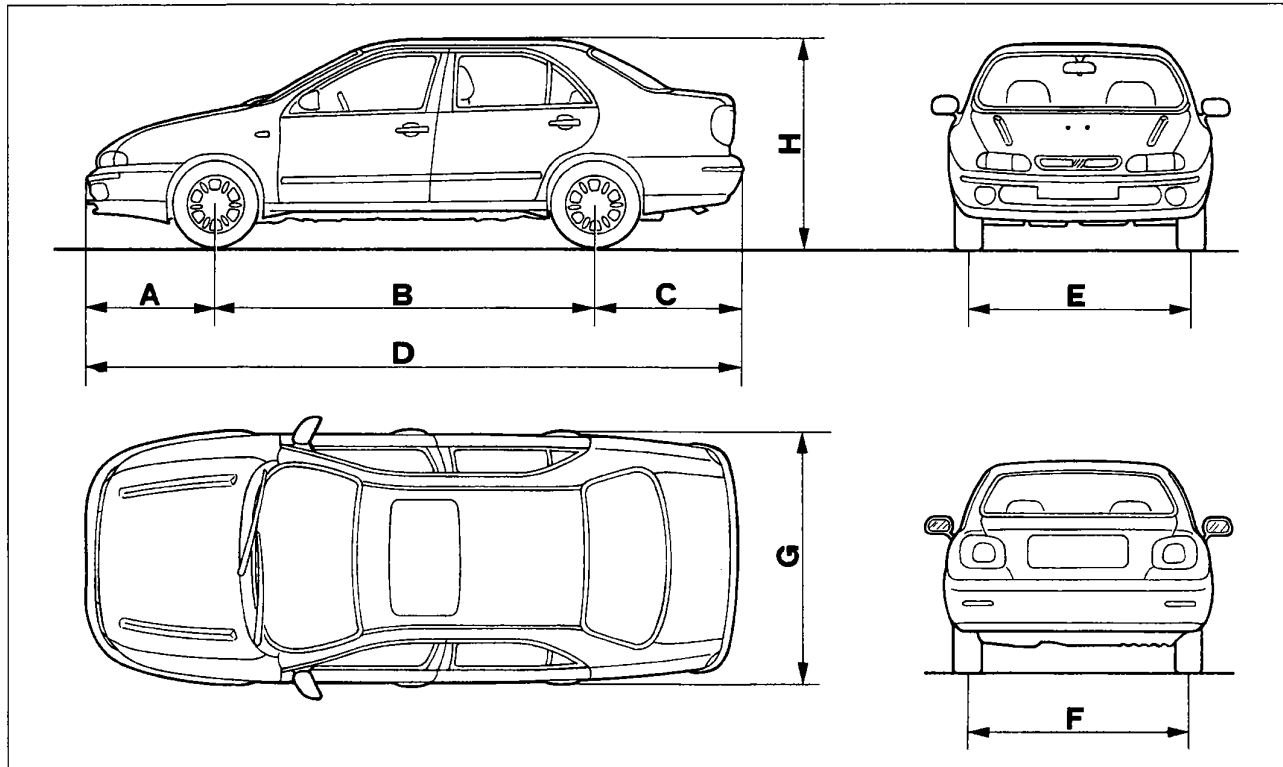

P4F008A01

Luggage compartment capacity (VDA regulations): 430 dm³
The height refers to an unladen vehicle

Engine types	Wheel rim	A	B	C	D	E	F	G	H
1242 16v	5½Jx14-37 6Jx15-43	881	2540	969	4390	1480 1470	1455 1440	1741	1425
1581 16v	5½Jx14-43 6Jx15-43	881	2540	969	4390	1470 1470	1440 1440	1741	1425
1581 16v C.A.	5½Jx14-43 6Jx15-43	881	2540	969	4390	1470 1470	1440 1440	1741	1425
1747 16v	5½Jx14-43 6Jx15-43	881	2540	969	4390	1470 1470	1440 1440	1741	1425
1998 20v	6Jx15-49	881	2540	969	4390	1475	1430	1741	1420
1910 TD	5½Jx14-37 6Jx15-43	884	2540	969	4393	1480 1470	1455 1440	1741	1425
1910 JTD	5½Jx14-43 6Jx15-43	884	2540	969	4393	1470 1470	1440 1440	1741	1425
2387 JTD	5½Jx15-46	884	2540	969	4393	1480	1435	1741	1420

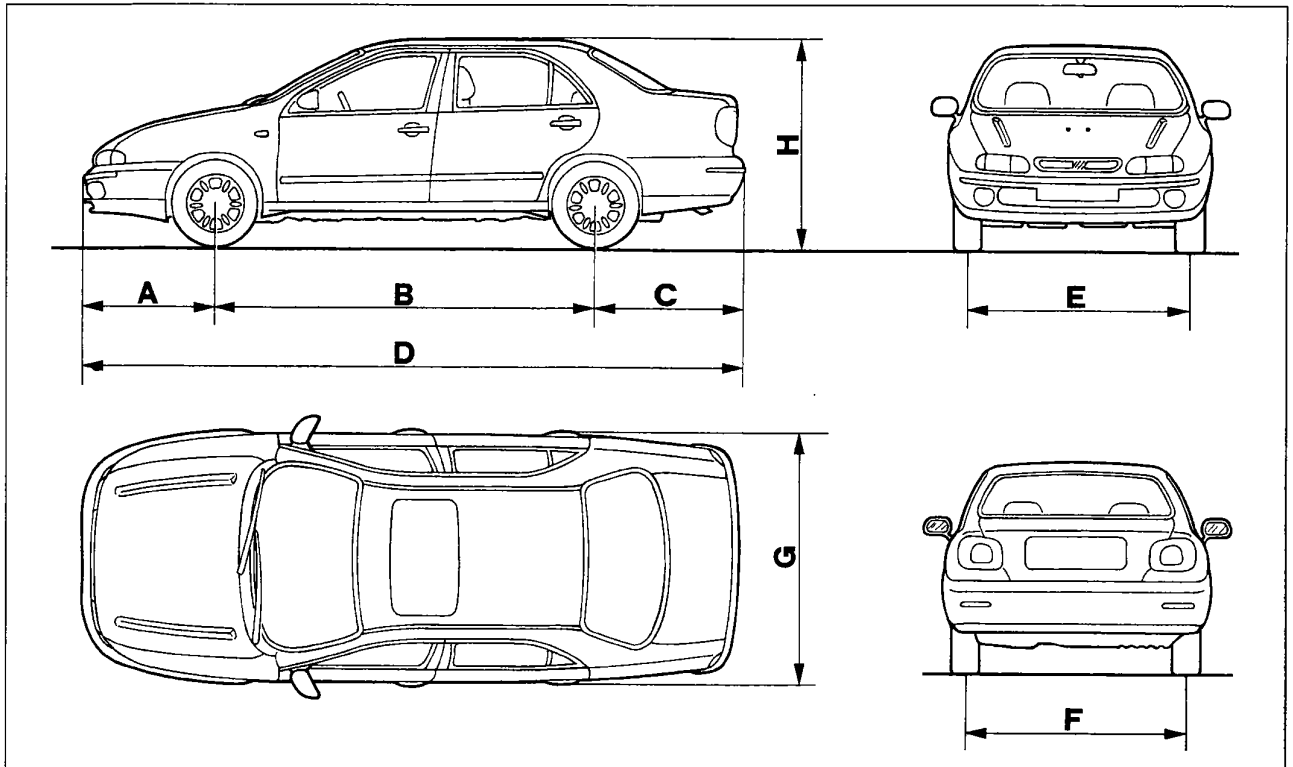

P4F008A01

Engine types	Wheel rim	A	B	C	D	E	F	G	H
1242 _{16v}	5½Jx14-37 6Jx15-43	881	2540	1066	4487	1480 1470	1455 1440	1741	1510
1581 _{16v}	5½Jx14-43 6Jx15-43	881	2540	1066	4487	1470 1470	1440 1440	1741	1510
1581 _{16v C.A.}	5½Jx14-43 6Jx15-43	881	2540	1066	4487	1470 1470	1440 1440	1741	1510
1747 _{16v}	5½Jx14-43 6Jx15-43	881	2540	1066	4487	1470 1470	1440 1440	1741	1510
1998 _{20v}	6Jx15-49	881	2540	1066	4487	1475	1430	1741	1505
1910 _{TD}	5½Jx14-37 6Jx15-43	884	2540	1066	4490	1480 1470	1455 1440	1741	1510
1910 _{TD}	5½Jx14-43 6Jx15-43	884	2540	1066	4490	1470 1470	1440 1440	1741	1510
2387 _{TD}	5½Jx15-46	884	2540	1066	4490	1480	1435	1741	1505

















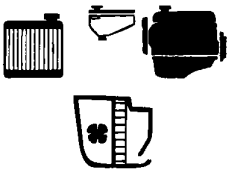

Introduction

Capacities

Marea- Marea Weekend

99 range













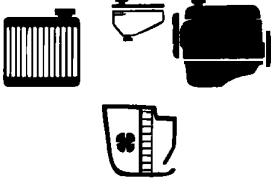

00.0

Description	Units	dm ³ (l)	kg	 16v	 16v	 16v	 20v
 Petrol ≥ O.R. 95 Unleaded		•		63	63	63	63
 50% + (▲) 	  	•		6 (5.6 ■)	7 (6.7 ■)	6 (5.6 ■)	7.6 (7.4 ■)
	Total capacity of cooling system						
 Petrol engines SELENIA 20K (SAE 10W/40)	 Total capacity	•		3.1	4.5	4.6	5.5
		•		2.75	4	4.1	4.7
	 Partial capacity (periodic replacement)	•		2.8 (2.5*)	3.8 (3.5*)	4.3 (3.9*)	5 (4.5*)
		•		2.5 (2.25*)	3.4 (3.1*)	3.85 (3.5*)	4.45 (4*)
 TUTELA ZC 75 Synth  <hr/> TUTELA GI/2 		•		1.7	1.98	1.65	1.98
		•		1.5	1.8	1.5	1.8
		•		-	4.3	-	-
		•		-	3.9	-	-

(▲) Distilled water

(■) For versions with air conditioning

(*) Engine sump only

Description		Units	dm ³ (l)	kg	 TD 75	 JTD	 JTD
	Diesel		•		63	63	63
 50% + (▲)			•		6 (5.6 ■)	6 (5.6 ■)	7.6 (7.4 ■)
		 	Total capacity of cooling system				
	Diesel Engines SELENIA Turbo Diesel (SAE 15W/40)		•		4.7	4.8	5.5
				•	4.2	4.25	4.7
			•		4.5 (4.2*)	4.3 (4*)	5 (4.7*)
				•	4 (3.75*)	3.75 (3.55*)	4.45 (4.2*)
	TUTELA ZC 75 Synth		•		1.65	1.65	1.98
				•	1.5	1.5	1.8

- (▲) Distilled water
- (■) For versions with air conditioning
- (*) Engine sump only











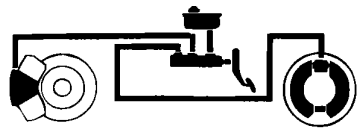

Introduction

Marea- Marea Weekend

Capacities

99 range

00.0

Description	Units	Quantity					
		dm ³ (l)	kg				
 TUTELA GI/A		-	0.8				
 TUTELA MRM2		-	0.003				
 TUTELA TOP4 (270°C)	 Total capacity	without ABS	0.40	-			
		without ABS	0.45	-			
 +  AREXONS			30%		5	-	
			- 10°C				50%
		- 20°C	100%				
		 + 	6.4 [▲] (6.8 ●)	-			

▲ Marea Weekend

● For the Marea Weekend 1747 16v - 1910 TD - 1910 JTD versions

Name of product	Description International designation	Application
SELENIA 20K	Semi-synthetic SAE 10W40 multigrade engine oil. Exceeds specifications ACEA A3-96/CCMC G5 and API SH	Temperature - 25°C - 40°C
SELENIA Turbo SAE 15W/40 Diesel	Mineral or semi-synthetic SAE 15W40 multigrade engine oil. Exceeds specifications ACEA B3-96/CCMC PD2 and API CD	Temperature - 15°C - 40°C (*)
TUTELA ZC75 SYNTH	SAE 75W EP oil. Satisfies standards MIL-L-2105 D and API GL 5	Manual gearboxes and differentials
TUTELA GI/A	"DEXRON II" type oil for hydraulic power assisted steering	Hydraulic power assisted steering
TUTELA GI/2	"DEXRON II" type oil for automatic transmissions	Automatic gearboxes
TUTELA MRM2	Water repellent, lithium soap based grease containing molybdenum disulphide, consistency NLGI = 2	Constant velocity joints
TUTELA TOP 4	Synthetic fluid, F.M.V.S.S. n° 116 DOT 4 ISO 4925, CUNA NC 956-01	Hydraulic brakes and hydraulically operated clutches
Arexons DP1	Mixture of alcohol, water and surface active agents CUNA NC 956-11	To be used undiluted or diluted in windscreen washer systems
Paraflu¹¹	Anti-freeze for cooling systems with mono-ethylene glycol base CUNA NC 956-16	Cooling circuits Percentage to be used 50% up to -35°C
Diesel Mix Arexons	Additive for diesel fuel with protective action for Diesel engines	To be mixed with diesel fuel (25 cc per 10 litres)

(*) For temperatures below -15°C, use SAE 10W40 grade oils



Introduction

Marea-Marea Weekend

Engine

99 range

00.10

 16v	 20v
--	---

SPECIFICATIONS

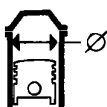
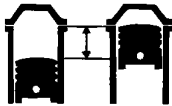
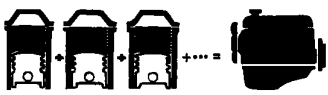
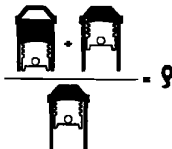
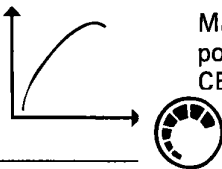
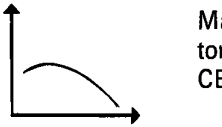
		Cycle	OTTO 4 stroke	
		Timing	TOHC	
		Type of fuel system	Integrated electronic injection - ignition	
	Number of cylinders		4	5
	Cylinder liner (bore)	mm	70.80	82
	Stroke	mm	78.86	75.65
	Capacity	cm ²	1242	1998
	Compression ratio		10.2	10.7 ± 0.15
	Max power CEE	kW	60	113
		(CV)	82	154
	Max torque CEE	rpm	5500	6500
		daNm (kgm)	11.3 11.5	18.6 (19.2)
		rpm	4250	3750

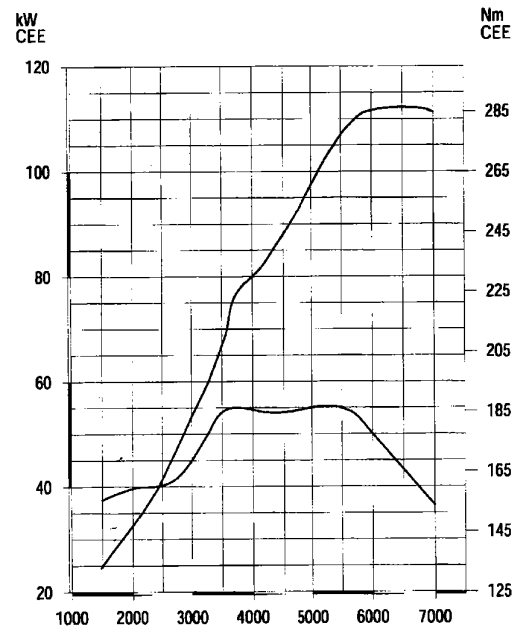
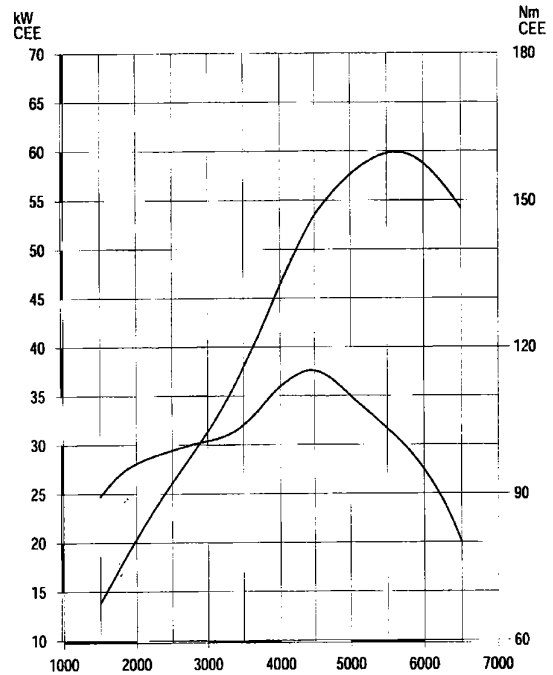

Power curves obtained through the CEE method

The power curves illustrated are those obtained using overhauled engines which have been run in, without a fan and with an exhaust silencer and air filter fitted, at sea level.

Technical data







Marea-Marea Weekend

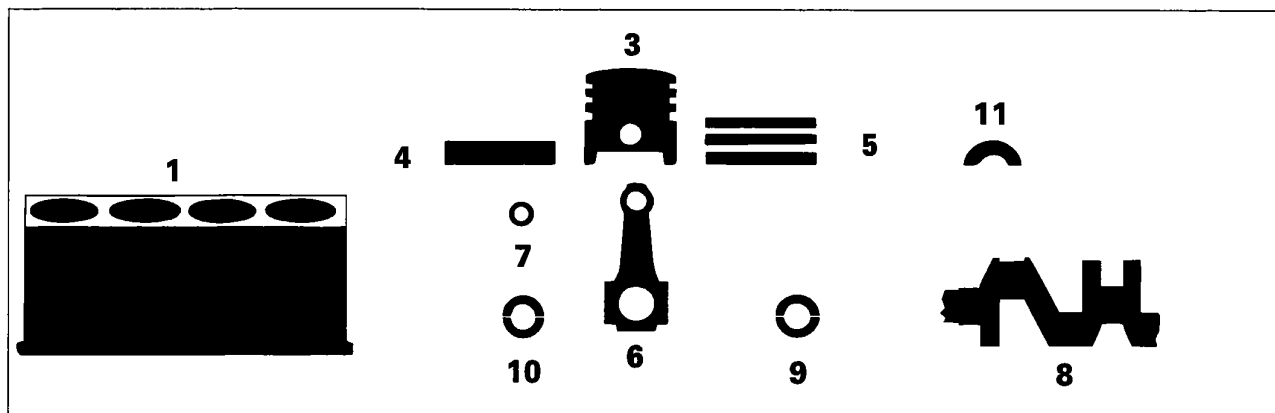



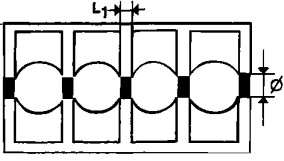

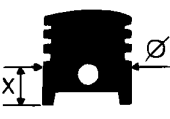





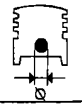







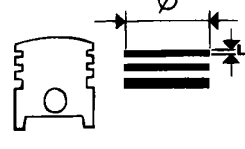



Engine: cylinder block/crankcase, crankshaft and associated

99 range

00.10



		 		
DESCRIPTION		Values in mm		
1  <p>Main bearing supports</p>	L	19.14-19.20	21.72-21.80	
	$\left. \begin{matrix} 1 \\ 2 \\ 3 \end{matrix} \right\} \varnothing$	1	51.705-51.709	63.705-63.718
		2	51.709-51.713	
		3	51.713-51.717	
1  <p>Cylinder liner/bore</p>	A	70.800-70.810	82.000-82.010	
	B	70.810-70.820	82.010-82.020	
	C	70.820-70.830	82.020-82.030	
3  <p>Piston</p>	X	6	12.5	
	$\left. \begin{matrix} A \\ B \\ C \end{matrix} \right\} \varnothing$	A	70.760-70.770	81.952-81.962
		B	70.770-70.780	81.959-81.971
		C	70.780-70.790	81.968-81.978
	$\varnothing \frac{GO}{A} / \frac{A}{T}$	0.4		
3  <p>Difference in weight between pistons</p>		± 5 g		
3-1  <p>Piston Cylinder liner/bore</p>	$\left. \begin{matrix} A \\ B \\ C \end{matrix} \right\} \varnothing$	0.030-0.050	0.038-0.058	
			0.039-0.061	
			0.042-0.062	

		 		
DESCRIPTION		Value in mm		
3	 Gudgeon pin housing ∅	17.982-17.986	20.002-20.007	
4	 Gudgeon pin ∅	17.970-17.974	19.996-20.000	
Gudgeon pin ∅  >		0.2		
4-3	 Gudgeon pin - Housing	0.008-0.016	0.002-0.011	
3	 Piston Ring Grooves	 1	1.190-1.230	1.220-1.240
		 2	1.190-1.230	1.210-1.230
		 3	2.490-2.530	2.010-2.030
5	 Piston rings	 1	1.170-1.190	1.180-1.160
		 2	1.175-1.190	1.190-1.170
		 3	2.475-2.490	1.990-1.970
∅  >		0.4		
5-3	 Piston rings Piston ring grooves	 1	0-0.06	0.040-0.080
		 2	0-0.055	0.020-0.050
		 3	0-0.055	0.020-0.060
5-1	 Opening at end of piston rings in cylinder liner	 1	0.200-0.400	0.200-0.350
		 2	0.250-0.450	0.250-0.500
		 3	0.200-0.450	0.250-0.500
6	 Small end bush or pin housing ∅₁	17.939-17.956	22.939-22.972	
	 Big end bearing housing ∅₂	45.128-45.138	51.354-51.366	

Technical data

Marea-Marea Weekend

Engine: cylinder block/crankcase, crankshaft and associated



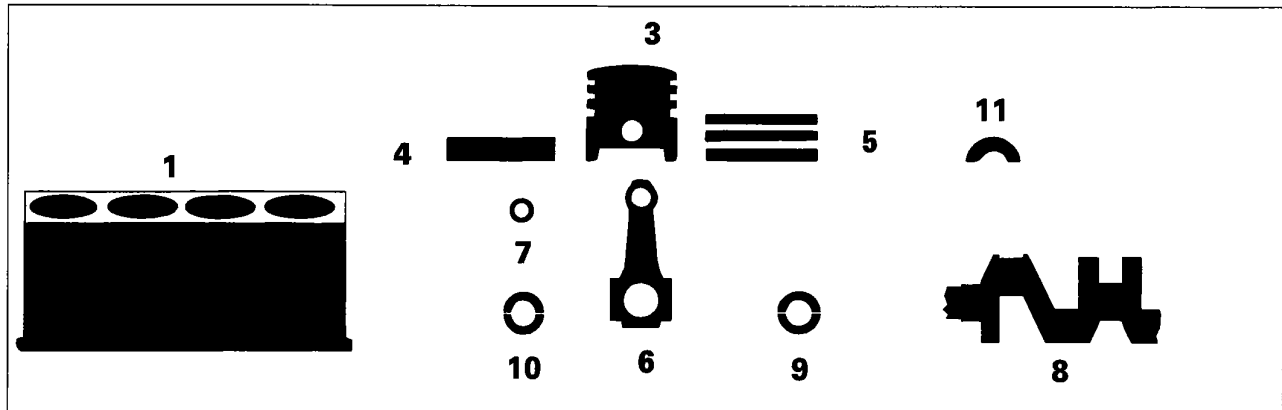

99 range

00.10

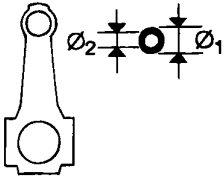

DESCRIPTION

Values in mm

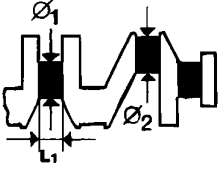
DESCRIPTION		Values in mm			
4-6	 Gudgeon pin - small end	0.014-0.035	-		
7	 Small end bush	$\varnothing 1$	23.007-23.027		
7	 Small end bush housing	$\varnothing 2$	20.006-20.012		
4-7	 Gudgeon pin Small end bush	-	0.006-0.020		
7-6	 Small end bush Bush housing	-	0.035-0.088		
8		Main journals $\varnothing 1$	1	47.982-47.988	59.994-60.000
			2	47.988-47.994	59.988-59.990
			3	47.994-48.000	59.982-59.980
		Crank pins $\varnothing 1$	A	41.990-42.008	48.238-48.240
			B	-	48.232-48.230
			C	-	48.226-48.230
			L1	23.975 - 24.025	26.575-26.625









		 1242 16v  1998 20v	
DESCRIPTION		Values in mm	
9 	Crankshaft bearings	1	1.836-1.840
		2	1.843-1.847
		3	1.848-1.852
	\varnothing  <	0.254 - 0.508	
9-8 	Big end bearings - Main journals	0.025-0.040	
10 	Big end housing	A	1.536-1.540
		B	1.539-1.543
		C	1.542-1.546
	\varnothing  <	0.254-0.508	
10-8 	Crankshaft bearings - Main journals	A	0.024-0.060
		B	-
		C	-
11 	Thrust washers	S	2.310-2.360
		S  >	0.127
11-8 	Crankshaft end float	0.055-0.265	
		0.059-0.161	

Diagram showing connecting rod-piston assembly and positioning in the engine

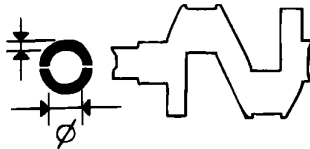
- Area where number of cylinder liner/bore to which connecting rod belongs is stamped
- Direction of rotation of engine
(The arrow shows the direction of rotation of the engine as seen from the timing side)

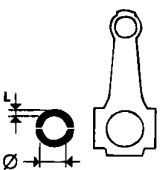
Value (in mm) of offset between connecting rod axis and piston axis

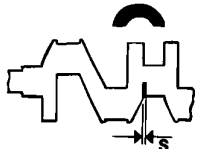
D=0.85- 1.15 (for 1242 16v)
D=0.10- 0.60 (for 1998 20v)

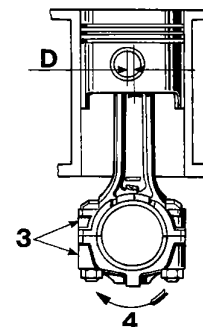

Technical data

Marea-Marea Weekend

Engine: cylinder head and valve gear components

99 range

00.10

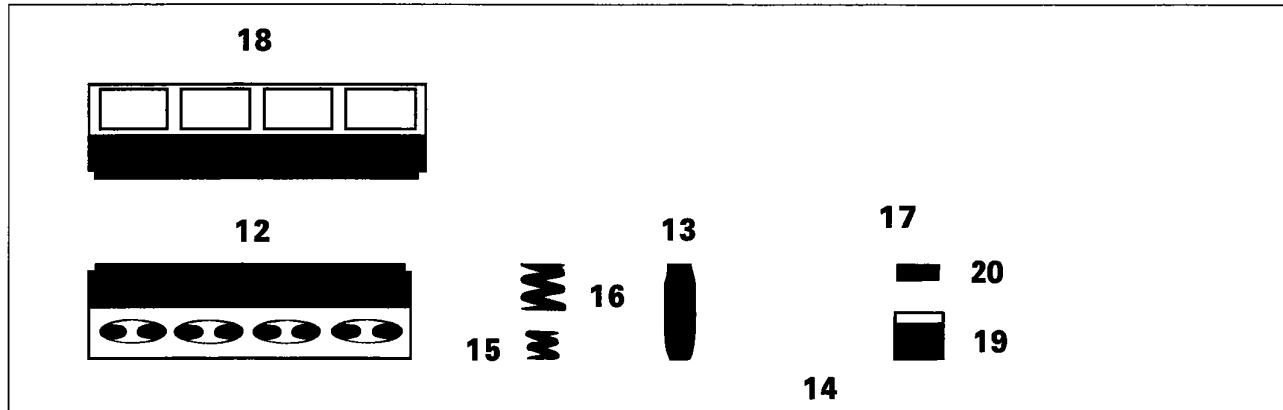









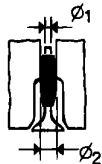



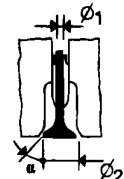

--	--

DESCRIPTION

Values in mm

Camshaft supports on cylinder head	\emptyset	-	26.045-26.070	
	L	-	19.100-19.150	
12	\emptyset	9.959-9.989	12.950-12.977	
 Valve seat	α		$45^{\circ} \pm 20'$	$45^{\circ} \pm 5'$
			$45^{\circ} \pm 20'$	$45^{\circ} \pm 5'$
	L		1.5	about 2
Volume of combustion chamber in cylinder head	cm ³	12.28	38.2	

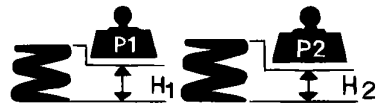
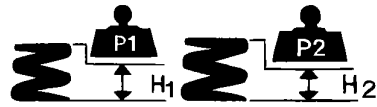
		1242 16v		1998 20v	
DESCRIPTION		Values in mm			
13	 Valve guide	$\phi 1$ 	6.022-6.040	7.022-7.040	
		$\phi 2$ 	10.010-10.030	13.010-13.030	
		$\phi 2$  >	-	0.05-0.010-0.25	
13-12	 Valve guide Bore in cylinder head		0.049-0.051	0.033-0.080	
12	Tappet housing In cylinder head	ϕ	-	33.000-33.025	
14	 Valve	$\phi 1$ 	5.974-5.992	6.975-6.930	
		$\phi 2$ 	22.250-22.250	29.900-30.200	
		α	-	45° 30' ± 5'	
		$\phi 1$ 	5.974-5.992	6.960-6.975	
		$\phi 2$ 	22.250-22.550	25.900-26.200	
		α	-	45° 30' ± 5'	
14-13	 Valve Valve guide		0.030-0.066	0.032-0.065	
				0.047-0.080	
15	 Inner valve spring	P1	-	11.08-12.07 daN	
		H1	-	29.5	
		P2	-	21.58-23.54 daN	
		H2	-	20	
16	 Outer valve spring	P1	22.5 daN	27.7-29.43 daN	
		H1	31	34	
		P2	42.3	48.46-52.38 daN	
		H2	23	24.5	

Technical data

Marea-Marea Weekend

Engine: cylinder head and valve gear components





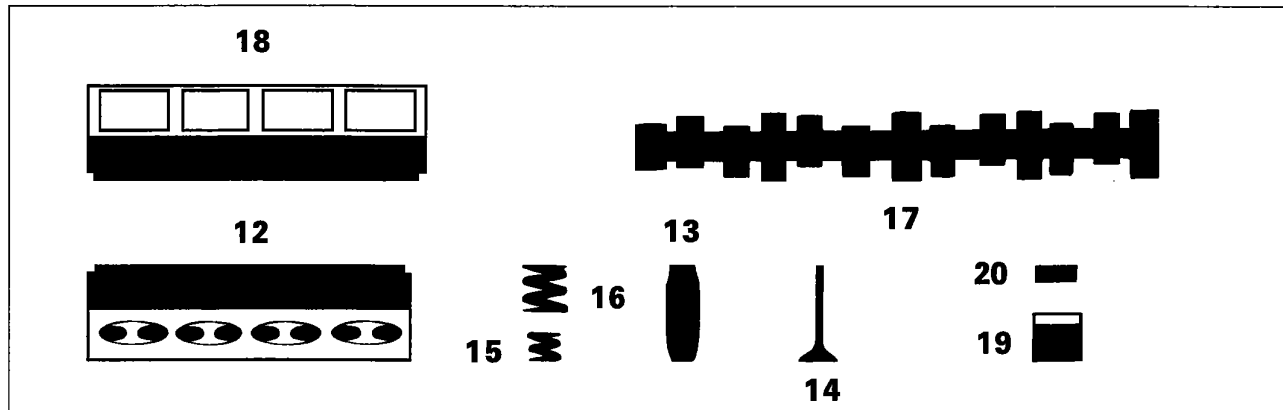

99 range

00.10

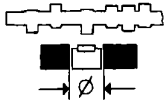



16v	20v
-----	-----

DESCRIPTION		Values in mm	
17a 17b Camshaft bearings	Ø1	35.000-35.015	-
	Ø2	48.000-48.015	-
	Ø3	49.000-49.015	-
	Ø	-	26.000-26.015
	L	-	19.250-19.330
17a Cam lift		7.5	9
		7.5	9
12-17a Camshaft bearings Cylinder head supports	Ø1	0.030-0.070	-
	Ø2	0.030-0.070	
	Ø3	0.030-0.070	
	radial	-	0.030-0.070
	axial	-	0.100-0.230
18 Camshaft supports in camshaft housing	Ø1	35.045-35.070	-
	Ø2	48.045-48.070	-
	Ø3	49.045-49.070	-
18 Tappet housings Ø		28.400-28.421	-

		1242 16v	1998 20v
DESCRIPTION		Value in mm	
19	 Tappet \varnothing	28.354 - 28.370	32.959 - 32.975
19-12	 Tappet Bore in cylinder head	-	0.025 - 0.066
19-18	 Tappet - Housing in camshaft housing	0.046 - 0.051	-
17-20	<p>clearance for timing check </p> <p> operational clearance </p> <p></p>	0.45	Hydraulic tappets

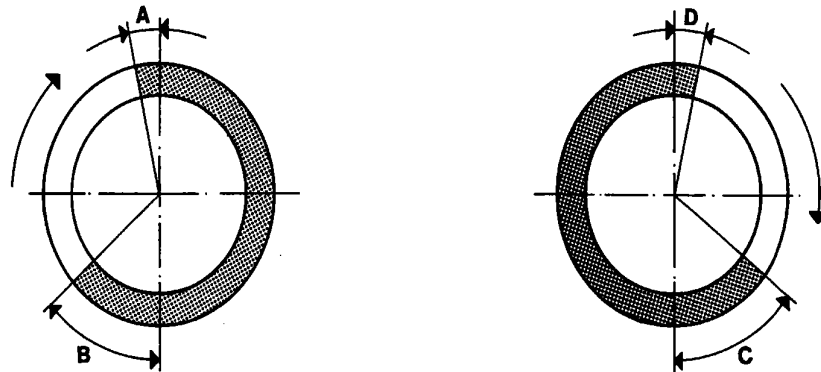
TIMING DIAGRAMS



		1242 16v	1998 20v
A	Inlet 	opens before T.D.C.	0°
B		closes after B.D.C.	9° (*) after T.D.C.
C	Exhaust 	opens before B.D.C.	32° 42'
D		closes after T.D.C.	49° (**)
			32° 42'
			0°
			0°

(*) With intervention of phase transformer opening 9° before TDC
 (**) With intervention of phase transformer closing 31° after BDC

Technical data



Marea-Marea Weekend





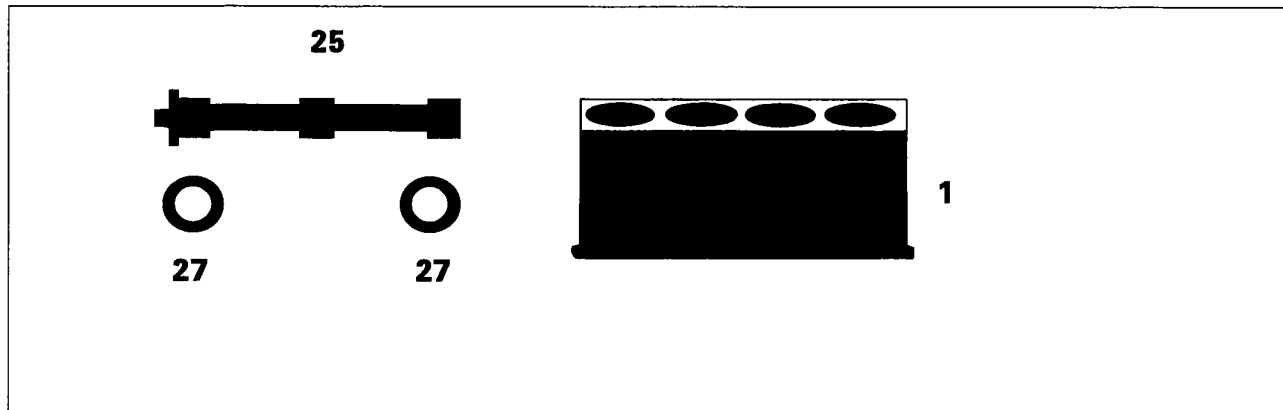

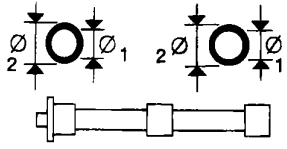
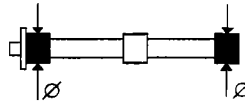
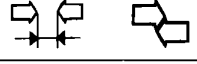
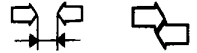

Engine: counter balance shaft

99 range



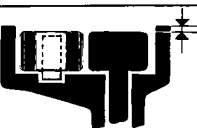



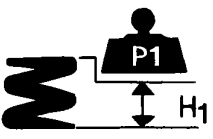

00.10



		 16v	 20v
DESCRIPTION		Values in mm	
25	Counter-balance shaft operation	-	through oil pump driven gear
27	 Ball bearings for counter-balance shaft	Ø1	- 19.900 - 20.000
		Ø2	- 46.989 - 47.000
25	 Counter-balance shaft bearings	Ø	- 19.980 - 19.993
1	Bearing seats in cylinder block/crankcase	Ø	- 46.975 - 47.000
27-1	 Ball bearings Crankcase seats	-	+ 0.011 - - 0.025
25-27	 Shaft bearings Ball bearings	-	+ 0.020 - - 0.003



	 16v	 20v
DESCRIPTION	Values in mm	
Engine lubrication circuit	forced circulation, via lobe geared pump with cartridge filter in series	forced circulation, via geared pump with cartridge oil filter in series
Oil pump	lobe gears	gears, located in crankshaft front cover
Pump operated	through crankshaft	through chain driven by the crankshaft
Oil pressure relief valve	incorporated in the crankshaft front cover	
Full flow filter	-	cartridge
Insufficient oil pressure sender unit	-	electrical
 between pump casing and Driven gear	0.100 – 0.210	-
 between edge of gears and pump casing	-	0.110 – 0.180
 between edge of gears and pump cover	0.025 – 0.070	-
 between upper edge of gears and pump cover	-	0.16 – 0.086
Full flow filter	cartridge	
Insufficient oil pressure sender unit	electrical	
 between drive gear and driven gear	0.30	
  when idling Operating pressure At a temperature of 100°C	1 bar	
	at 4000 rpm	
	P ₁	11.73 – 12.51
	H ₁	35
Oil pressure relief valve spring		

00.10

COOLING SYSTEM		 16v	 20v	
Cooling circuit		coolant circulation via centrifugal pump, radiator, expansion tank and fan operated by thermal switch	coolant circulation via centrifugal pump, radiator and two speed fan operated by engine control unit	
Water pump operation		through belt		
 Thermal switch to engage fan		1st stage	90° + 94°C	-
		2nd stage	95° + 99°C (■)	-
		1st stage	85° + 89°C	-
		2nd stage	95° + 94°C (■)	-
Operated by control unit to engage fan		1 st speed	-	96° + 97°C
		2 nd speed	-	101 + 102°
		1 st speed	-	93° + 94°C
		2 nd speed	-	98° + 99°C
Engine coolant thermostat	opening	81° - 85°C		
	max opening	103°C	101°C-105°C	
	valve travel	≥ 9.5 mm		
Fitting clearance between impeller vanes and pump casing		0.4 + 0.9 mm	0.4 + 0.95 mm	
Pressure for checking system water tightness		0.98 bar		
Pressure for checking exhaust valve on expansion tank cap		0.98 bar		

(■) Versions with climate control

Checking idle concentration of pollutant emissions	CO (%)	HC (p.p.m.)	CO ₂ (%)
Upstream of the catalytic converter	0.4 - 1	≤ 600	≥ 12
Downstream of the catalytic converter	≤ 0,35	≤ 90	≥ 13

	 16v	 20v
FUEL SYSTEM		
Type	BOSCH 1.5.5 MPI electronic integrated injection/ignition	BOSCH Motronic MPI electronic integrated injection/ignition
Pump	electric immersed in the tank	
Flow rate	≥ 110 l/h	≥ 120 l/h
Fuel pressure regulator setting	3 bar	

INTEGRATED ELECTRONIC INJECTION/IGNITION SYSTEM COMPONENTS

Injection/ignition system electronic control unit	Bosch 0.261.204.578	Bosch 0.261.204.271
Butterfly casing	Bosch 0.280.750.013	-
Motorized butterfly casing	-	Bosch 0.250.003.052
Absolute pressure sensor	Bosch 0.261.230.013	-
Injector	Bosch 0.280.155.816	Bosch 0.280.155.770
Electric fuel pump	Bosch 0.580.313.011	
Air flow meter	-	Bosch 0.281.002.199
Engine coolant temperature sensor	ELTH 2690350 – SYLEA 402.183.01	
Lambda sensor	Bosch 0.258.006.071	Bosch 0.258.006.072
Fuel vapour solenoid valve	Bosch 0.280.142.330	Bosch 0.280.142.340
Detonation sensor	Bosch 0.261.231.007	Bosch 0.261.231.131
Hall effect injection timing sensor	-	Bosch 0.232.101.036
Top Dead Centre and rpm sensor	Bosch 0.281.210.124	Bosch 0.261.210.160

Technical data

Marea-Marea Weekend



Engine

99 range

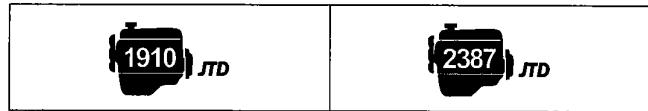
00.10

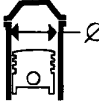
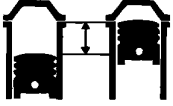
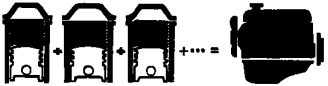
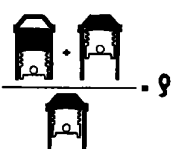
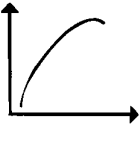
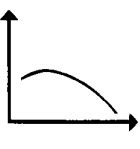

SPECIFICATIONS

	Cycle	Diesel 4 stroke		
	Timing	SOHC		
	Engine balancing	-	through 1 counter-balance shaft	
	Type of fuel system	Direct injection Turbocharger + intercooler		
	Number of cylinders	4 in line	5 in line	
	Cylinder liner (bore)	mm	82	
	Stroke	mm	90.4	
	Capacity	cm ²	1910 2387	
	Compression ratio		18.45 ± 0.5 18.6 ± 0.5	
	Max power	KW (CEE) (CV) (CEE)	77 (105)	100 (136)
		rpm	4000	4200
	Max torque	daNm (CEE) (kgm) (CEE)	20 (20.4)	31 (31)
		rpm	1500	2000

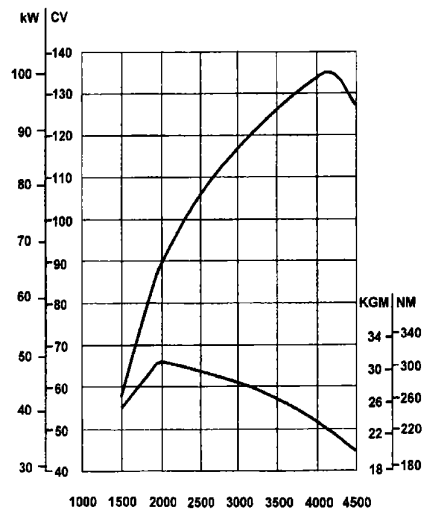
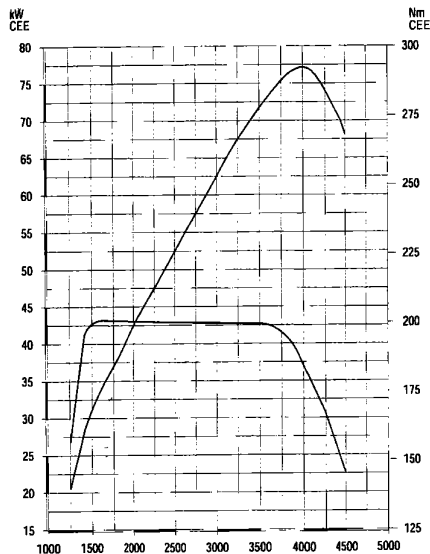

Test bench cycles for overhauled engines

During the bench test for overhauled engines, it is not advisable to let the engine reach maximum speed, but to stick to the figures recommended in the table; complete the running in of the actual engine in the vehicle.

Test speed rpm	Time in minutes	Load on the brakes
800 ÷ 1000	10'	no load
1500	10'	no load
2000	10'	no load

Typical engine curves obtained using the CEE method

The power curves illustrated can be obtained with the engine overhauled and run in, without a fan, with a silencer and air filter fitted, at sea level.

Technical data

Marea-Marea Weekend







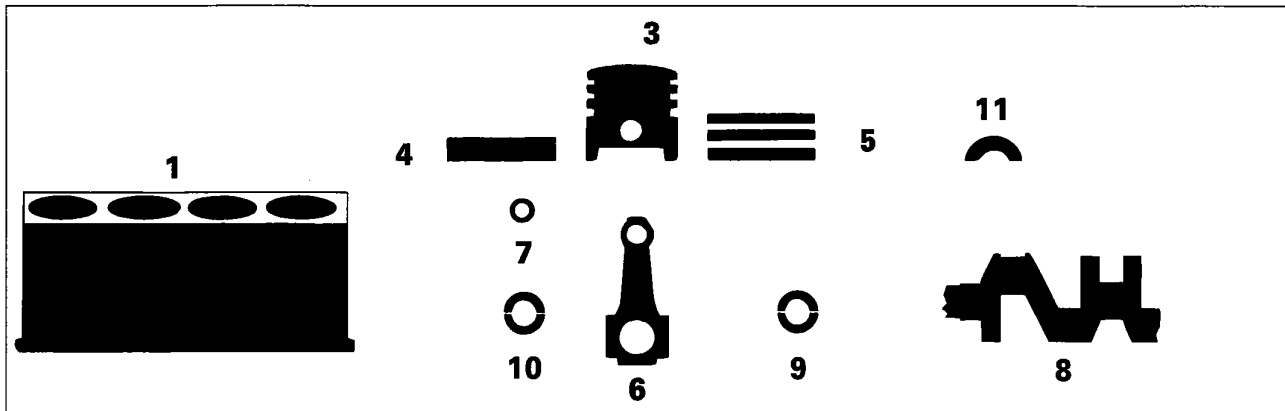



Engine: cylinder block/crankcase, crankshaft and associated

99 range

00.10

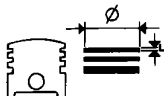

DESCRIPTION		Values in mm	
	L	21.750 - 22.250	21.720 - 21.800
	L1	22.300 - 22.700	-
	L2	21.750 - 22.250	-
1 Main bearing supports 	ϕ	63.691 - 63.732	
	A	82.000 - 82.010	
	B	82.010 - 82.020	
	C	82.020 - 82.030	
3 Piston 	X	8	10
	A	81.920 - 81.930	81.930 - 81.940
	B	81.930 - 81.940	81.940 - 81.950
	C	81.940 - 81.950	81.950 - 81.960
ϕ $>$		0.4	
3-1	Piston projection	0.845 - 1.105	0.637 - 1.162
3	Difference in weight between pistons	± 5 g	
3-1	Piston Cylinder liner	0.070-0.090	0.060 - 0.080

		 		
DESCRIPTION		Values in mm		
3	 Gudgeon pin housing	∅	25.999 - 26.004	25.991 - 25.996
3	 Piston ring grooves	1	2.685 - 2.715 (*)	2.675 - 2.705 (1)
		2	2.020 - 2.040	2.010 - 2.030
		3	3.020 - 3.040	
4	 Gudgeon pin	∅	25.982 - 25.988	
	 >		-	
4-3	 Gudgeon pin - Housing		0.011 - 0.022	0.003 - 0.014
5	 Piston rings	1	2.568 - 2.597 (**)	2.575 - 2.595
		2	1.970 - 1.995	1.970 - 1.990
		3	2.970 - 2.990	2.975 - 2.990
	 >		0.4 - 0.6	0.4
5-3	 Piston rings Piston ring grooves	1	0.088 - 0.147	-
		2	0.025 - 0.070	0.020 - 0.060
		3	0.030 - 0.070	0.030 - 0.065
5-1	 Opening at end of piston rings in cylinder liner	1	0.250 - 0.400	
		2	0.250 - 0.500	
		3	0.250 - 0.500	

(*) Measured on the 73.8 mm diameter

(1) Measured on the 79 mm diameter

(**) Measured 1.5 mm from the outside edge

Technical data

Marea-Marea Weekend







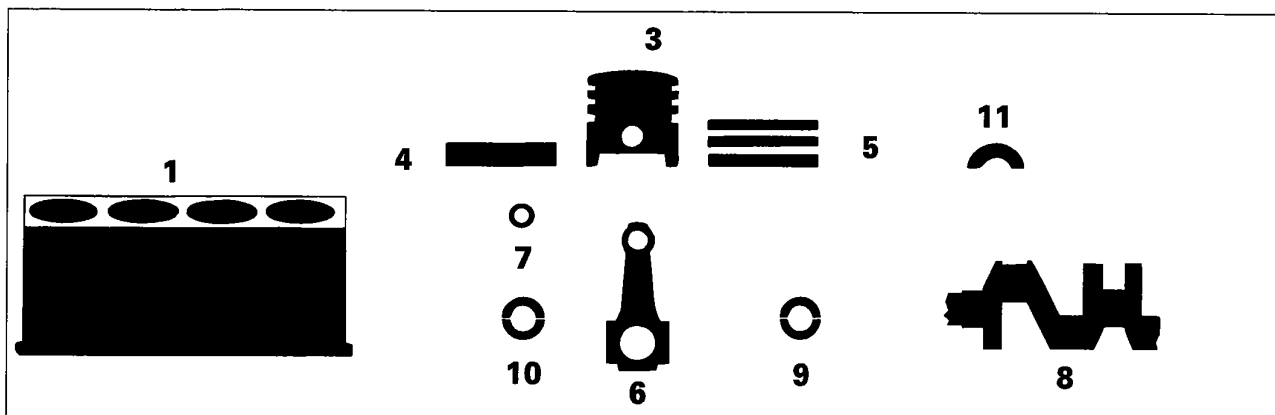

Engine: cylinder block/crankcase, crankshaft and associated

99 range

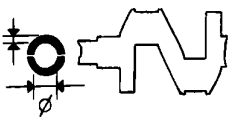
00.10

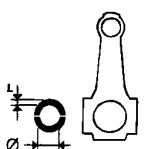

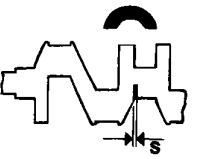
		1910 JTD		2387 JTD	
DESCRIPTION		Values in mm			
6	Small end bush or pin housing	Ø1	28.939 - 28.972		
	Big end bearing housing	Ø2	53.897 - 53.909	53.883 - 53.923	
6	Difference in weight between connecting rods		± 2,5 g		
7	Small end bush	Ø1	29.018 - 29.038		
		Ø2 Gudgeon pin	26.006 - 26.012		
4-7	Gudgeon pin Small end bush		0.018 - 0.030		
7-6	Small end bush Bush housing		0.046 - 0.099		
8	Main journals	Ø1	1	59.994 - 60.000	
			2	59.988 - 59.994	
			3	59.982 - 59.988	
	Crank pins	Ø2	A	50.799 - 50.805	
			B	50.793 - 50.799	
			C	50.787 - 50.793	
	L		26.80 - 27.20	26.575 - 26.625	
	L1		25.90 - 26.10	-	

			
DESCRIPTION		Values in mm	
9 	Crankshaft bearings	1	1.836 - 1.840
		2	1.839 - 1.843
		3	1.842 - 1.846
	\emptyset  <		0.254 - 0.508
9-8 	Crankshaft bearings - Main journals	0.011 - 0.071	0.025 - 0.052
10 	Big end bearings	A	1.527 - 1.531
		B	1.530 - 1.534
		C	1.533 - 1.537
	\emptyset  <		0.254 - 0.508
10-8 	Big end bearings - Main journals	0.030 - 0.056	0.016 - 0.070
11 	Thrust washers	S	2.469 - 2.485
		S  >	
11-8 	Crankshaft end float	0.049 - 0.211	0.059 - 0.221

Technical data





Marea-Marea Weekend

Engine: cylinder head and valve gear components

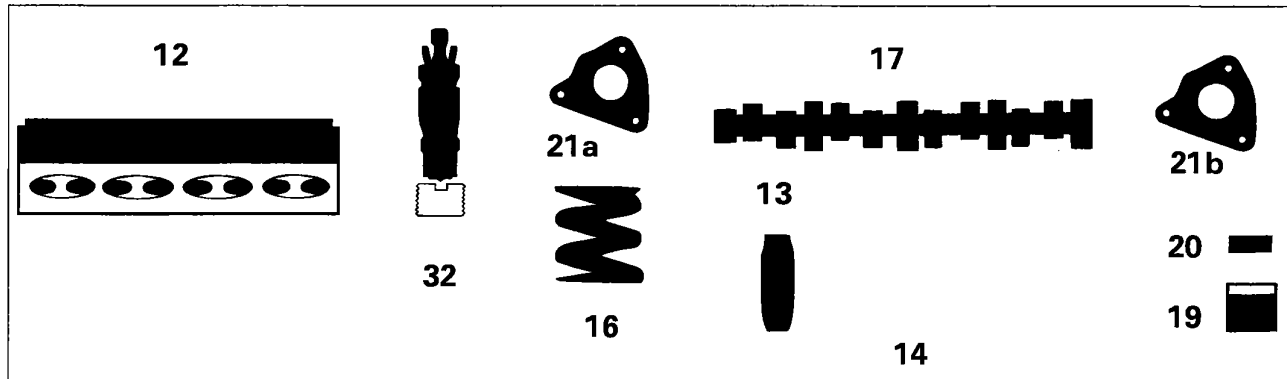

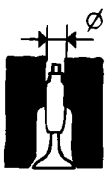
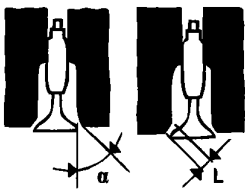

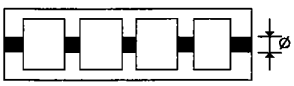
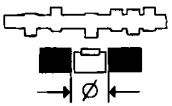

99 range

00.10

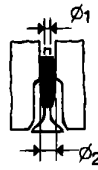

		1910 JTD	2387 JTD	
DESCRIPTION		Values in mm		
 <p>Valve guide bore in cylinder head</p>	Ø	13.950 - 13.977		
	α		45°±20'	45°±5'
			45°±20'	45°±5'
12 Valve seat	L	About 2.7		
	Ø	26.045 - 26.070		
	L*	19.100 - 19.150		
<p>L = Camshaft supports</p>  <p>Tappet housing</p>	Ø	37.000 - 37.025		

(*) Cap measurement

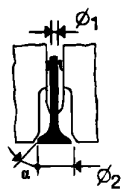
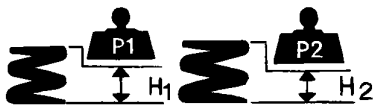
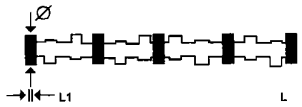
				
DESCRIPTION		Values in mm		
13  Valve guide	\varnothing_1 	8.022 - 8.040		
	\varnothing_2	14.010 - 14.030		
	\varnothing_2  >	0.05 - 0.10 - 0.25		
13-12  Valve guide Bore in cylinder head		0.033 - 0.080		
14  Valve	\varnothing_1	7.974 - 7.992		
	\varnothing_2	35.40 - 35.60	37.40 - 37.70	
		α	45° 30' ± 15'	45° 30' ± 5'
	α	\varnothing_1	7.974 - 7.992	
		\varnothing_2	34.40 - 34.60	30.90 - 31.20
		α	45° 30' ± 5'	
14-13 Valve - Valve guid		0.030 - 0.066		
16  Valve spring	P_1	36.69 - 39.63 daN	36.7 - 36.9 daN	
	H_1	36		
	P_2	55.91 - 60.82 daN	56 - 61 daN	
	H_2	26.5		
17 	\varnothing	26.000 - 26.015		
	L	23.10 - 23.70	-	
	L_1	19.25 - 19.30	19.25 - 19.33	

Technical data

Marea-Marea Weekend

Engine: cylinder head and valve gear components

99 range

00.10

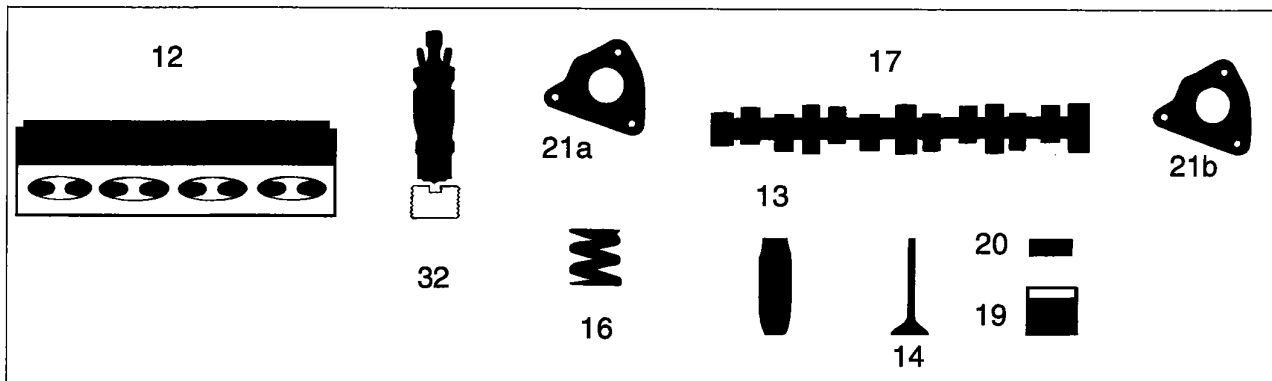

		1910 JTD		2387 JTD	
DESCRIPTION		Values in mm			
17-12		radial	0.030 - 0.070		
		axial	0.100 - 0.230		
17	 Cam lift		8.5		
			8.5		
19	 Tappets \varnothing	36.975 - 36.995			
19-12	 Tappet - Cylinder head	0.005 - 0.050			
20	 Shim S	3.25 - 4.90		3.25 - 4.70	
17-20	 clearance for timing check		0.50		
			0.50		
	operational clearance		0.30 ± 0.05		
			0.35 ± 0.05		

TIMING DIAGRAMS

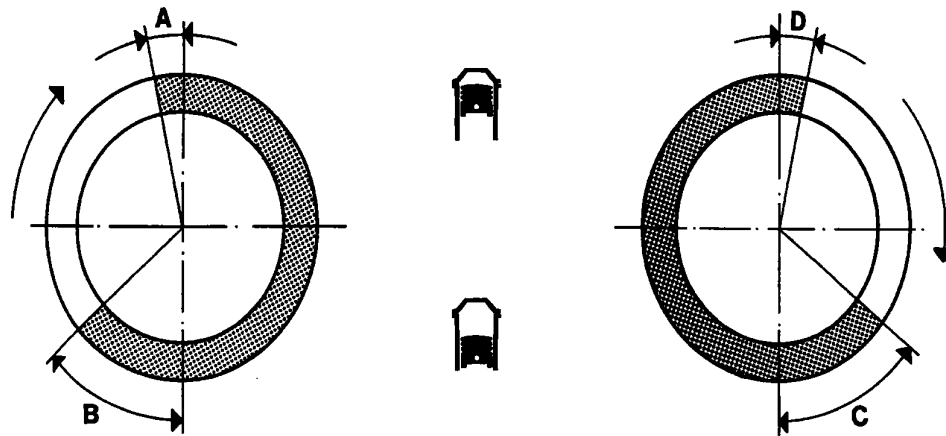

TIMING ANGLES

			1910 JTD	2387 JTD	
A	Inlet		opens after TDC	0°	6°
B			closes after BDC	32°	26°
C	Exhaust		opens after BDC	32°	26°
D			closes after TDC	0°	6°

Technical data

Marea-Marea Weekend





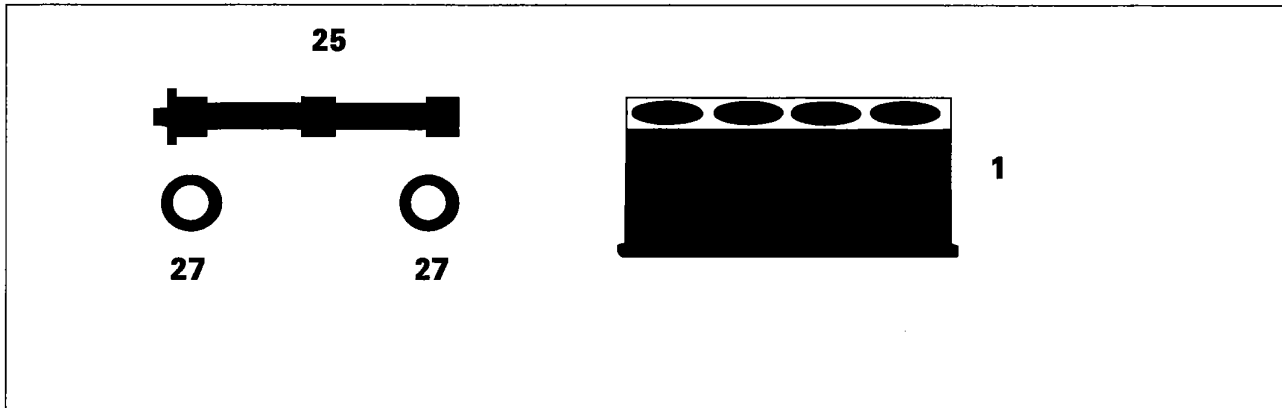

Engine: counter-balance shafts

99 range

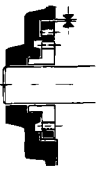
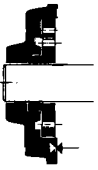
00.10



DESCRIPTION		Values in mm	
25	Counter-balance shafts	n° 1	
	Shaft operation	through oil pump driven gear	
27	 Ball bearings for counter-balance shaft	Ø ₁	19.900 - 20.000
		Ø ₂	46.989 - 47.00
25	 Counter-balance shaft bearings	Ø	19.980 - 19.993
1	Bearing seats in cylinder block/crankcase	Ø	46.975 - 47.000
27-1	 Ball bearings Crankcase seats		+0.011 - -0.025
25-27	 Shaft bearings Ball bearings		+0.020 - -0.003

		
LUBRICATION		Values in mm
Engine lubrication circuit		forced circulation, via lobe geared pump with cartridge filter in series
Oil pump		lobe gears
Pump operated		through crankshaft
Oil pressure relief valve		incorporated in crankshaft front cover
	between pump casing housing and driven gear	0.080 - 0.186
	between upper side of gears and pump cover	0.025 - 0.056
Full flow filter		cartridge
Insufficient oil pressure sender unit		electrical
 	Operating pressure at a temperature of 100°C	3.43 - 4.9 bar
  	P ₁	6.27 - 7.06 daN
Oil pressure relief valve spring	H ₁	36

Technical data





Marea-Marea Weekend



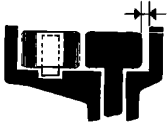
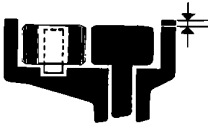

Engine: lubrication

99 range

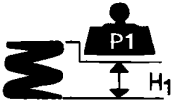
00.10



LUBRICATION		Values in mm
Engine lubrication circuit		forced circulation, via geared pump with cartridge filter in series
Oil pump		geared, located in the crankshaft front cover
Pump operated		by chain driven by crankshaft
Oil pressure relief valve		incorporated in the crankshaft front cover
	between edge of gears and pump casing	0.110 - 0.180
	between upper edge of gears and pump casing	0.016 - 0.086
Full flow filter		cartridge
Insufficient oil pressure sender unit		electrical
	between drive gear and driven gear	0.30
 	Operating pressure at a temperature of 100°C	5 - 5.5 bar
	P ₁	11.73 - 12.51 daN
	H ₁	35
Oil pressure relief valve spring		

COOLING SYSTEM			
Cooling circuit	coolant circulation via centrifugal pump, radiator and two speed fan operated by engine control unit		
Water pump operated	by belt		
Operated by control unit to engage fan		1 st speed	96° - 97°C
		2 nd speed	101° - 102°C
		1 st speed	93° - 94°C
		2 nd speed	98° - 99°C
Engine coolant thermostat	opening	88°	
	max opening	103°	
	valve travel	≥ 9.5 mm	
Fitting clearance between impeller vanes and pump casing		0.40 - 0.75 mm	
Pressure for checking radiator water tightness	1 ± 0,1 bar		
Pressure for checking calibration of exhaust spring on expansion tank	1 ± 0.1 bar		

FUEL SYSTEM

Firing order	1 - 2 - 4 - 5 - 3
Rotary piston injection pump	RADIALJET
Nozzle	-
Injector setting pressure	≤ 1300 bar

Technical data

Marea-Marea Weekend

Engine: fuel system

99 range

00.10

BOSCH COMMON RAIL ELECTRONIC FUEL SYSTEM COMPONENTS	
Control unit	Bosch 0.281.001.928
Flow meter	Bosch 0.281.002.199
Engine coolant temperature sensor	Jaeger 402.183.01
Diesel temperature sensor	Bosch 0.281.002.209
Rpm sensor	Bosch 0.281.002.214
Timing sensor	Bosch 0.281.002.213
Turbocharger pressure sensor	Bosch 0.281.002.215
Fuel pressure sensor	Bosch 0.281.002.210
Injector	Bosch 0.445.110.002
Pre-heating control unit	Bosch 0.281.003.215
Heater plugs	Bosch 0.250.202.028
E.G.R. solenoid valve	46419651

INJECTION SYSTEM COMPONENTS	
	Values in mm
Injection system electronic control unit	0.281.001.935
Supercharging pressure sender unit	0.281.002.215
Fuel temperature sensor	0.281.002.209\
Electric fuel pump	0.580.464.984
Air flow meter	0.280.218.019
Fuel pressure sensor	0.281.002.210
Engine coolant temperature sensor	0.281.002.209
Timing sensor	0.281.002.213
Top Dead Centre and rpm sensor	0.281.002.214
Potentiometer on accelerator pedal	0.281.002.202
Pressure regulator (DVR)	-
E.G.R. solenoid valve	Borg Warner - Bitron

Technical data



Marea-Marea Weekend

Engine: supercharging

99 range

00.10





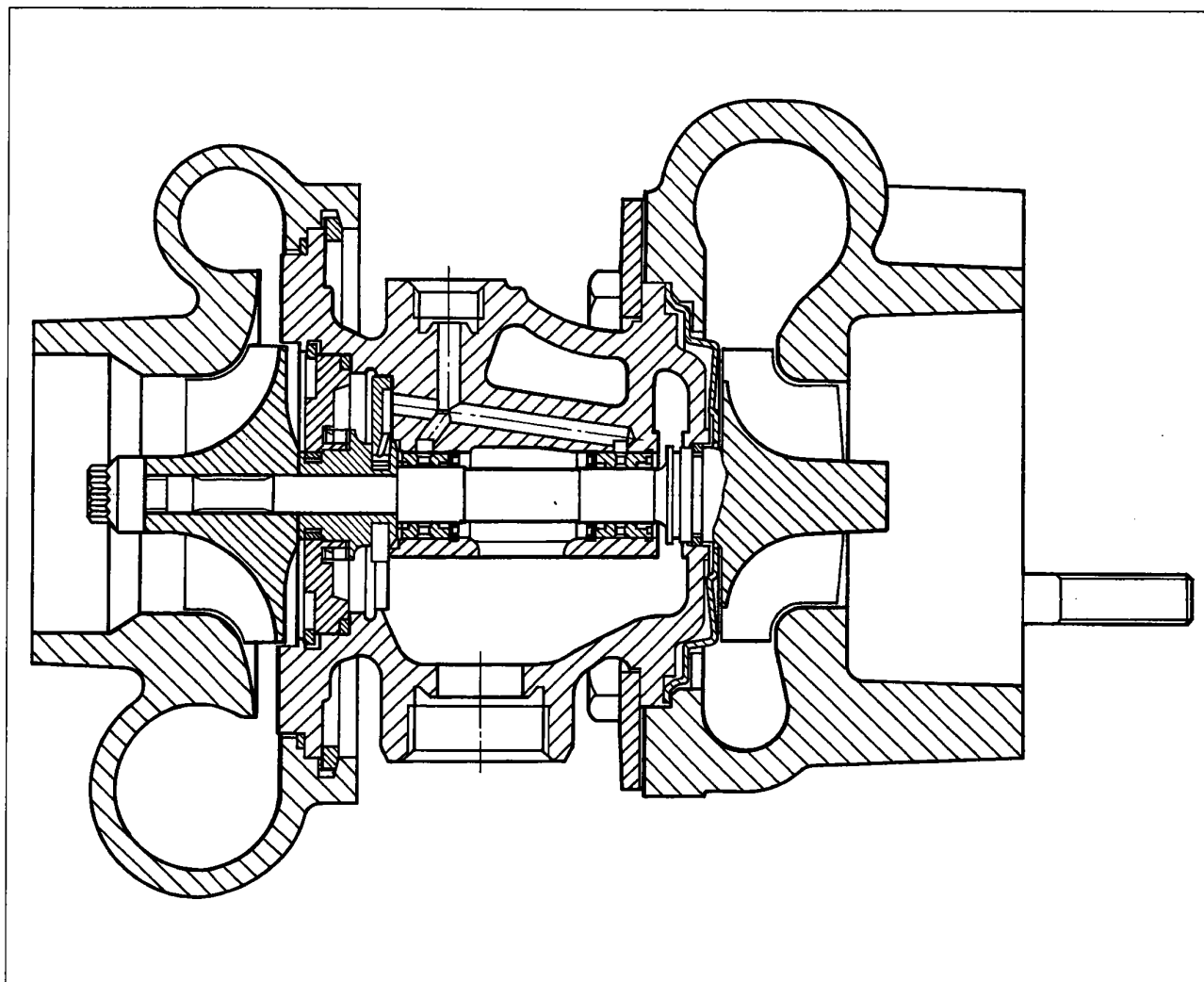

SUPERCHARGING Turbocharger operated by exhaust gases with waste-gate pressure valve and air/air heat exchanger (intercooler)

COOLING SYSTEM	 1910 JTD	 2387 JTD
Turbocharger: type	Garret GT 15	IHI VL6 variable geometry
Maximum supercharging pressure	1.05 bar	







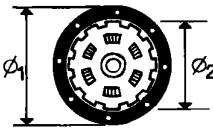
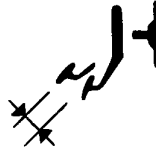
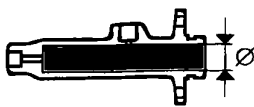
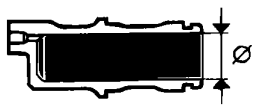





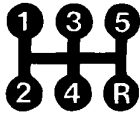
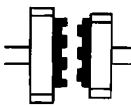

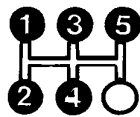

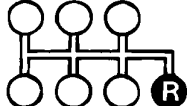

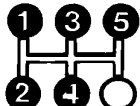
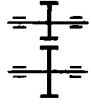













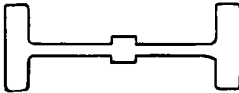





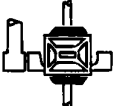





4A46A01

CROSS SECTION OF TURBOCHARGER

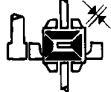





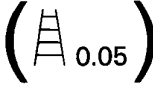





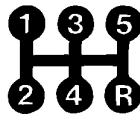
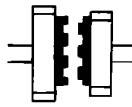

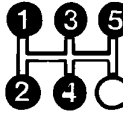
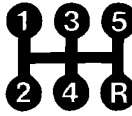

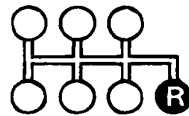

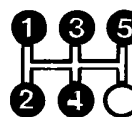
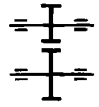
		 16v	 20v	 JTD	 JTD
		Values in mm			
Type		 dry, single plate with bearing			
Operating mechanism		 Spring			
Spring loading	daN	430	600	485	600
 Driven disc	\varnothing_1	200	230	215	235
	\varnothing_2	137	155	147	165
	Distance between pedal in end of travel position and pedal in rest position	163		136	
Clutch operation		mechanical		hydraulic	
	Clutch operating pump \varnothing	-		16.05 (3/4")	
	Operating cylinder \varnothing	-		25.4 (1")	











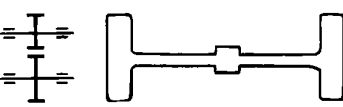





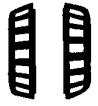

00.21.27

		 16v	 20v
			
		Type	
GEARBOX		C. 514.5.13	C.510.5.21
 Synchronizers	spring ring (Porsche type) 		
	baulk ring type 		
 Gears	straight toothed 		
	helical toothed 		
  Gear ratios		3.909	3.545
		2.158	2.238
		1.480	1.520
		1.121	1.156
		0.897	0.919
		4.071	3.909

DIFFERENTIAL		 16v	 20v		
		Ratio crown wheel and pin-ion reduction	4.071 (14.57)	3.733 (15/56)	
 Ratio at the wheels			15.914	13.233	
			8.786	8.354	
			6.025	5.674	
			4.564	4.315	
			3.652	3.431	
			16.573	14.593	
	 conical roller bearings				
 Adjustment of bearing pre-loading			 by shims		
		 mm	0.05	-	1.70 - 2.60
Thickness of shims			0.10	2.00 - 3.00	-
	Recommended interference for exact bearing pre-loading	mm	bearings not loaded = 0.12 bearings loaded (350daN) = 0.08		
	Clearance between planet/satellite gears	mm	≤ 0.10		
 Adjustment of clearance between planet/satellite gears			no adjustment is carried out	 by shims	no adjustment is carried out
		 mm	-	0.80 - 1.25	-
Thickness of shims					

00.21.27

			
			
		Type	
GEARBOX		C. 510.5.21	C.530.5.31.01
 Synchronizers	spring ring (Porsche type) 	-	
	baulk ring type 		
 Gears	straight toothed 		
	helical toothed 		
  Gear ratios		3.909	3.800
		2.238	2.235
		1.444	1.360
		1.029	0.971
		0.767	0.707
		3.909	3.545
  Ratio crown wheel and pinion reduction	3.150 (20/63)	3.353 (17/57)	

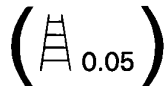
DIFFERENTIAL		1910 JTD		2387 JTD	
 <p>Ratio at the wheels</p>		12.568	12.741		
		7.049	7.494		
		4.549	4.560		
		3.241	3.256		
		2.416	2.370		
		12.313	11.887		
 <p>Differential internal housing bearing</p>	 <p>conical roller bearings</p>				
 <p>Adjustment of bearing pre-loading</p>	 <p>by shims</p>				
 <p>Thickness of shims</p>	 <p>mm 0.05</p>	1.70 - 2.60	1.25 - 1.60		
 <p>Bearing rolling torque</p>		-	0.10 - 0.14		
 <p>Recommended interference for exact bearing pre-loading</p>	mm	Bearings not loaded = 0.12 bearings loaded (350 daN) = 0.08			
 <p>Clearance between planet/satellite gears</p>	mm	≤ 0.10	0.10 - 0.20		
 <p>Adjustment of clearance between planet/satellite gears</p>		no adjustment	 <p>by shims</p>		
 <p>Thickness of shims</p>	 <p>(0.05) mm</p>	-	1.8 - 2.2		

Technical data

Marea-Marea Weekend





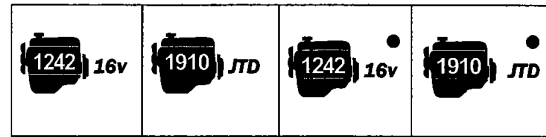

Brakes

99 range



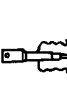

00.33



FRONT BRAKES

	Disc	\varnothing	257
			11.80-12.10
			19.80 - 20.10
			11.10
			18.55
			10.20
			18.20
	Brake pads	S < allowed	1.5
	Caliper	\varnothing	54
	Master cylinder (pump)	\varnothing	22.225 (7/8")
	Brake servo		Iso-Vac 8» pneumatic vacuum acting on all four wheels
	Distance of hydraulic piston push rod from master cylinder support plate	L	22.45 - 22.65

REAR BRAKES







	Drum	\varnothing	203.10 - 203.40	228.30-228.60
			204.10	229.30
			204.70	230.00
	Shoes	S < allowed	1.5	
	Cylinders	\varnothing	22.00	
	Reduction ratio		0.36	-
			-	0.36

(●) Weekend Version

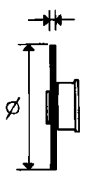



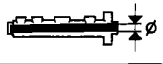

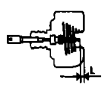
FRONT BRAKES

Values in mm

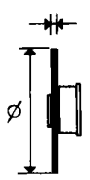
 <p>Disc</p>	\emptyset	283.800 - 284.200
		21.800 - 22.100
		20.55
	S < allowed	20.20
 <p>Brake pads</p>	S < allowed	1.5
 <p>Caliper</p>	\emptyset	54
 <p>Master cylinder (pump)</p>	\emptyset	23.81 (15/16")
 <p>Brake servo</p>		Iso-Vac 8" + 7" pneumatic vacuum acting on all four wheels
 <p>Distance of hydraulic piston push rod from master cylinder support plate</p>	L	22.45 - 22.65

REAR BRAKES

 <p>Disc</p>	\emptyset	240	
	S {		10.80 + 11.10
			10.10
		< allowed	9.20
 <p>Brake pads</p>	S < allowed	1.5	
 <p>Caliper</p>	\emptyset	34	
	Load proportioning valve	acting on rear wheels	
	Ratio (reduction)	0.36	





Technical data





Steering





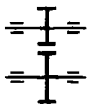
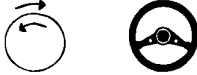

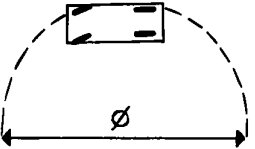
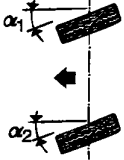
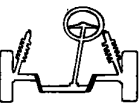
Marea-Marea Weekend

99 range

00.41

ENGINE TYPE	 1242 16v	 1998 20v	 2387 TD
	 1910 JTD		

Type	 Rack and pinion power assisted			
 Ratio	 no. of turns lock to lock	3	2.9	2.8
		 rack travel	142±1.5 mm	137±1.5 mm
 Turning circle	10.7 11 11.4			
 Steering angle	outer wheel α_1	31° ± 30'		
	inner wheel α_2	38° ± 30'		
 Steering column	 with 2 universal joints			

ENGINE TYPE	 Wheel rim		 Tyre Tubeless radial, type	 Inflation pressure in bar			
	pressed steel	light alloy		Front		Rear	
				average load	heavy load	average load	heavy load
 1242 16v	5½J×14»-37	6J×15»-43	175/70 R14 84T 195/55 R15 84V	2.1 bar	2.2 bar	2.3 bar	2.5 bar
 1998 20v	-	6J×15»-43	195/60 R15 88V	2.3 bar	2.5 bar	2.3 bar	2.5 bar
 1910 JTD	5½J×14»-37 5½J×14»-43	6J×15»-43	175/70 R14 84H (■) 185/65 R14 86H (■)(▲) 195/55 R15 84V	2.1 bar	2.2 bar	2.3 bar	2.5 bar
 2387 JTD	-	5½J×15»-43	195/60 R15 88V	2.4 bar	2.5 bar	2.3 bar	2.5 bar
SPARE WHEEL (*)	4B×15"-43.3	4B×15»-35	185/65 R14 86H (▲) 125/80 R5 95m	4.2 bar			

The tyre inflation pressure for the Marea Weekend with a commercial load (1 person + 500 kg) is 2.3 bar for the front wheels for all versions excluding the 1998 20V and 2387 JTD versions for which it is 2.5, whilst the rear tyre inflation pressure is 3 bar for all versions.

- (*) Speed limit: 80 km/h
- (●) Special tyres for the Marea version
- (■) Special tyres for the Marea Weekend version
- (▲) For the TAXI version

Technical data

Marea-Marea Weekend

Wheels



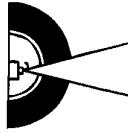

99 range

00.44

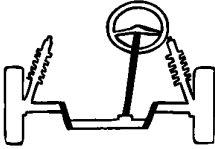

unladen vehicle (■)

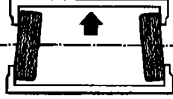
WHEEL GEOMETRY

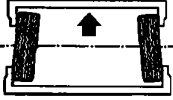
 <p>front suspension</p>	<p>camber (**)</p> 	<p>- 38' 10» ± 30'</p>
	<p>caster (**)</p> 	<p>2° 51' ± 30'</p>
	<p>toe in</p> 	<p>-1 - 1 mm</p>
	<p>offset front wheel ▲</p>	<p>0°</p>
 <p>rear suspension</p>	<p>camber (**)</p> 	<p>0° 52' 00» ± 30'</p>
	<p>toe in (**)</p> 	<p>0.85 ± 2 mm</p>
	<p>thrust angle rear wheels ▲</p>	<p>0°</p>

(**) Angles cannot be adjusted

(■) With the tyres inflated to the correct pressure and the vehicle in running order with 5 litres of fuel

(▲) Angular values, which cannot be adjusted, used for the correct alignment of the vehicle

Front suspension independent, Mac Pherson type with transverse lower track control arms secured to an auxiliary crossmember. Offset coil springs and double acting, telescopic, hydraulic shock absorbers. Anti-roll bar connected to the telescopic damper.

ENGINE TYPE	 16v	 20v
-------------	--	---

Shock absorbers

Type	Double acting, telescopic, hydraulic		
Open (start of damping action)	mm	508 ± 2.5	501 ± 2.5
Closed (metal against metal)	mm	361 ± 2.5	354 ± 2.5
Travel	mm	147	

Anti-roll bar

Diameter of anti-roll bar	mm	18
---------------------------	----	----

 1910 JTD	 2387 JTD
---	--

Shock absorbers





Type: double acting, telescopic	low pressure gas		
Open (start of damping action)	mm	508 ± 2.5	501 ± 2.5
Closed (metal against metal)	mm	361 ± 2.5	354 ± 2.5
Travel	mm	147	

Anti-roll bar

Diameter of anti-roll bar	mm	18
---------------------------	----	----

00.44

CLASSIFICATION OF SPRINGS ACCORDING TO VARIOUS VERSIONS AND ENGINE TYPES



VERSIONS	ENGINE TYPES			
	 1242 TD	 1998 20v	 1910 JTD	 2387 JTD
Standard	G		D	
Standard with ABS	G		D	
With air conditioning	F		C	
With air conditioning and all options	F			
With air conditioning, ABS and all options	F		C	
With air conditioning and ABS			C	
With ABS (fitted as standard)		B		A
With ABS (fitted as standard) and air conditioning		B		A
With ABS (fitted as standard), air conditioning and all options		B		A

SPECIFICATIONS OF VARIOUS SPRINGS

Coil springs	A	B	C	D	E	F	G
Diameter of wire mm	13.6 ± 0.05		13.5 ± 0.05		13.2 ± 0.05		
Number of coils	3.75						
Direction of coil	Clockwise						
Height of spring released mm	468	449	448	434	425	413	405
Load under which height of spring is 173 mm daN	461 ± 18	432 ± 17	417 ± 17	397 ± 16	368 ± 15	350 ± 14	338 ± 13
The springs have been divided into two categories identifiable by a mark yellow (*) for those with a height of >173 mm under a load of: green (*) for those with a height of ≤ 173 mm under a load of:	461 daN	432 daN	417 daN	397 daN	368 daN	350 daN	338 daN

(*) Springs of the same type must be fitted

Rear suspension independent with track control arms anchored to an auxiliary crossmember. Variable flexibility coil springs and anti-roll bar. Gas shock absorbers with low friction coefficient lower bushes

ENGINE TYPE	 16v	 20v	 JTD	 JTD
--------------------	---	---	---	---

Coil spring

Diameter of wire	mm	12.3 ± 0.1
Number of coils		5.93
Direction of coil		clockwise
Height of spring released	mm	3.16
Height of spring under a load of: 360 daN	mm	184
The springs are divided into two categories, identifiable by a mark: yellow (1) for those: 360 daN height of mm under a load of _____		> 184
green (1) for those: 360 daN height of mm under a load of _____		≤ 184

(1) Springs of the same type must be fitted.

Shock absorbers





Type		double acting, telescopic, gas
Open (start of damping action)	mm	321 ± 2
Closed (metal against metal)	mm	224 ± 2
Travel	mm	97

Anti-roll bar

Diameter of anti-roll bar	mm	17
---------------------------	----	----

00.44

Rear suspension independent with track control arms anchored to an auxiliary crossmember. Variable flexibility coil springs and anti-roll bar. Gas shock absorbers with low friction coefficient lower bushes.

ENGINE TYPE	 16v	 20v	 JTD	 JTD
-------------	---	--	---	---

Coil spring

Diameter of wire	mm	12.8 ± 0.1
Number of coils		5.93
Direction of coil		clockwise
Height of spring released	mm	322
Height of spring under a load of: 432 daN	mm	184
The springs are divided into two categories, identifiable by a mark:		
yellow (1) for those: 432 daN height of mm under a load of		> 184
green (1) for those: 432 daN height of mm under a load of:		≤ 184





(1) Springs of the same type must be fitted.

Shock absorbers

Type		double acting, telescopic, gas
Open (start of damping action)	mm	321 ± 2
Closed (metal against metal)	mm	224 ± 2
Travel	mm	97

Anti-roll bar

Diameter of anti-roll bar	mm	17
---------------------------	----	----

	 16v	 20v	 JTD	 JTD
STARTER MOTOR	M. Marelli E80E-12v-0,9 kW	BOSCH Ø 74,2 12v – 1.1 Kw (with reduction gear)	BOSCH Ø 78.5 – 12V – 2.0 kW (with reduction gear) M. Marelli M70R-12V-1,8 kW (with reduction gear)	M. Marelli E9ER-12V-2,2 kW (with reduction gear)
ALTERNATOR	M. Marelli A115I-14V- 38/65A M. Marelli A127IR-14V- 50/85A (●)	M. Marelli A127IR-14V- 50/85A M. Marelli A127IR-14V- 55/100A (●)	M. Marelli A127IR-14V- 50/85A M. Marelli A127IR-14V- 55/100A	M. Marelli A127IR-14V- 55/100A (1) BOSCH 14V-60/120A (2)
VOLTAGE REGULATOR	BUILT IN ELECTRONIC			
BATTERY	12V-50Ah-250A	12V-50Ah-250A 12V-60Ah-320A (▲)	12V-60Ah-380A 12V-70Ah-450A (▲)	12V-65Ah-450A
IGNITION SYSTEM	Bosch M1.5.5 MPI integrated elec- tronic injection/ignition	Bosch Motronic ME 3.1 MPI integrated elec- tronic injection/ignition	-	-
IGNITION COIL	BOSCH 0.221.503.407	BOSCH 0.261.210.160	-	-
SPARK PLUGS	FIAT RA4HCX FIAT DCPR8EKC	CHAMPION RC8 BYC	-	-
PRE-HEATING ELECTRONIC CONTROL UNIT	-	-	BOSCH 0.281.003.215	BOSCH 0.281.003.015
ENGINE FUEL SYSTEM ELECTRONIC CONTROL UNIT	-	-	BOSCH 0.281.001.928	BOSCH 0.281.001.935
HEATER PLUGS	-	-	BOSCH 0.250.202.028	

- (●) For vehicles with air conditioning
- (▲) TAXI version only
- (1) Validity also extended to vehicles with air conditioning
- (2) For vehicles with air conditioning and additional heater



Technical data

Marea-Marea Weekend

Electrical equipment: starting



99 range

00.55

STARTER MOTOR		 16v	 20v
Type		M. Marelli E80-12V-0,9 kW	BOSCH Ø 74,2 12V - 1.1 kW (with reduction gear)
Voltage	V	12	
Nominal power	kW	0.9	1.1
Rotation, pinion side		clockwise	
No. of poles		4	
Winding		series	
Engagement		free wheel	
Operation		Solenoid	
End float of armature shaft	mm	0.1 - 0.5	
Data for bench test			
Operating test (*):			
current	A	180 (200)	360 - 380
speed	rpm	1720 (2200)	1150
voltage	V	9.5 (9.8 - 10)	8.15
torque developed	daNm	0.37 (0.38)	1.30
Engagement test (*):			
current	A	324 (440)	680 - 700
voltage	V	7.1 (7.6)	4.9
torque developed	daNm	≥ 0.97 (≥ 1.25)	3.11
Free running test (*):			
current	A	40 (44 - 48)	60 - 80
voltage	V	11.4 (11.4-11.5)	4.9
speed	rpm	8500 - 9000 (11400-12300)	4040
Relay	{ pull in Ω hold in Ω	0.30 - 0.32 (0.32)	0.33 - 0.37
Winding resistance (*)		1.2 - 1.3 (1.09)	1.13 - 1.27
Lubrication		VS ⁺ SAE 10W	
Internal splines and Shaft bushes			
Engagement sleeve and intermediate disc		TUTELA MR3	

(*) Data obtained at an ambient temperature of 20°C

NOTE When overhauling it is not necessary to undercut the insulator between the commutator bars

STARTER MOTOR													
		BOSCH DIAM 78.5 - 12V - 2.0 kW (with reduction gear)		M. Marelli M70R-12V-1.8 kW (with reduction gear)	M. Marelli E95R-12V-2.2 kW								
Type													
Voltage	V	12											
Nominal power	kW	2.0	1.8	2.2									
Rotation, pinion side		clockwise											
No. of poles		6	4	4									
Winding		permanent magnets	series-parallel	series-parallel									
Engagement		free wheel											
Operation		solenoid											
End float of armature shaft	mm	0.1 - 0.5		0.15 - 0.45									
Data for bench test													
Operating test (*):													
current	A	500	400	600									
speed	rpm	1950	1400	1400									
voltage	V	7.30	9.60	7.9									
torque developed	daNm	1.30	1.40	1.6									
Engagement test (*):													
current	A	1200	1100 - 1150	1110 - 1150									
voltage	V	5.5	4.4 - 4.6	4.4 - 4.6									
torque developed	daNm	3.0	5.0	≥ 3.9									
Free running test (*):													
current	A	70 - 80	120 - 140	120 - 140									
voltage	V	11.5	11	11									
speed	rpm	5450 - 5750	4750 - 5000	4500 - 4750									
Relay	<table border="0"> <tr> <td rowspan="2" style="font-size: 3em; vertical-align: middle;">}</td> <td>pull in Ω</td> <td>0.4</td> <td>0.30 - 0.37</td> <td>0.23 - 0.27</td> </tr> <tr> <td>hold in Ω</td> <td>1.7</td> <td>1.2 - 1.3</td> <td>0.93 - 1.07</td> </tr> </table>	}	pull in Ω	0.4	0.30 - 0.37	0.23 - 0.27	hold in Ω	1.7	1.2 - 1.3	0.93 - 1.07			
			}	pull in Ω	0.4	0.30 - 0.37	0.23 - 0.27						
hold in Ω	1.7	1.2 - 1.3		0.93 - 1.07									
Winding resistance (*)													
Lubrication		VS ⁺ SAE 10W											
Internal splines and shaft bushes													
Engagement sleeve and intermediate disc		TUTELA MR3											

(*) Data obtained at an ambient temperature of 20°C.

NOTE When overhauling it is not necessary to undercut the insulator between the commutator bar.

Technical data

Marea-Marea Weekend

Electrical equipment: recharging

99 range

00.55

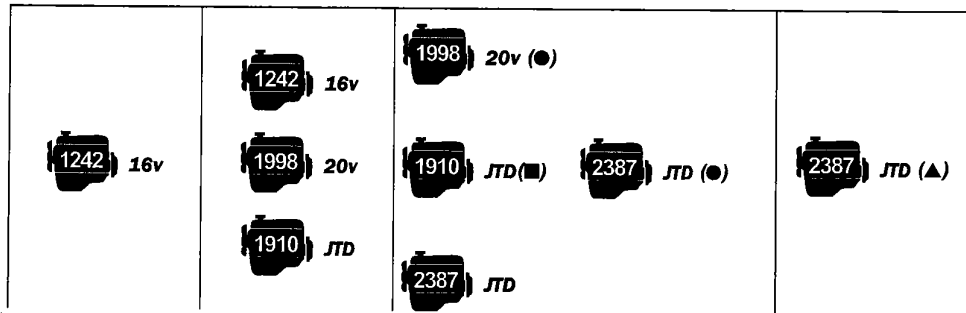

ALTERNATOR

Type	A115I-14V 38/65A	A127IR-14V 50/85A	A127IR – 14V 55/100A	Bosch 14V 60/120
Nominal voltage of system	V 14			
Maximum current	A 65	85	100	120
Nominal current at 1800 rpm	rpm 38	50	55	60
Nominal current at 6000 rpm	A 65	85	100	120
Field winding resistance between the two slip rings (*)	Ω 2.4	2.6	-	-
Direction of rotation (seen from control side)	Clockwise			
Diode power rectifiers	Bridge			

(*) Data obtained at an ambient temperature of 20°C.

(●) For vehicles with air conditioning

(■) Supplied as an alternative

(▲) For vehicles with air conditioning and additional heater

VOLTAGE REGULATOR

Type	Built in electronic	
	RTM 151A (1)	RTM 151 B
Alternator speed for test	rpm 7000	
Thermal stabilization corrector	A -	
Test current	A -	
Regulation voltage (*)	V 13.4 - 14.6	

(*) Data obtained at an ambient temperature of 23°C.

(1) Specific to 1242 16V version.

INTEGRATED ELECTRONIC INJECTION/IGNITION CONTROL MODULE	
Type	Bosch 0.261.204.578
Firing order	1 - 3 - 4 - 2

IGNITION COIL WITH 4 HIGH TENSION INTAKES

Make		Bosch
Type		0.221.503.407
Ohmic resistance of primary winding at 20°C	Ω	0.45 + 0.55
Ohmic resistance of secondary winding at 20°C	Ω	12000 + 14600

TOP DEAD CENTRE AND RPM SENSOR

Make and type		Bosch 0.281.210.124
Sensor winding resistance at 20°C	Ω	486 + 594
Distance (gap) between sensor and crankshaft pulley tooth	mm	0.8 + 1.5

SPARK PLUGS

Make and type		FIAT RA4 HCX FIAT DCPR BEKC
Thread		M 14 × 1.25
Electrode gap	mm	0.8

Technical data

Marea- Marea Weekend

Electrical equipment: electronic injection/ignition

99 range

00.55

INTEGRATED ELECTRONIC INJECTION/IGNITION SYSTEM



Make	Bosch 0.261.204.271
Firing order	1 - 2 - 4 - 5 - 3

IGNITION COIL (1 PER SPARK PLUG)

Make	Bosch
Type	0.221.504.014
Ohmic resistance of primary winding at 20°C	Ω 0,4
Ohmic resistance of secondary winding at 20°C	Ω 8500

TOP DEAD CENTRE AND RPM SENSOR

Make and type	Bosch 0.261.210.160
Sensor winding resistance at 20°C	Ω 774 + 946
Distance (gap) between sensor and crankshaft pulley tooth	mm 0.8 + 1.5

DETONATION SENSOR

Make	Bosch
Type	0.261.231.131

SPARK PLUGS

Make and type	CHAMPION RC8BYC
Thread	M 14 x 1.25
Electrode gap	mm 0.8

Tool number	NAME OF TOOL	ENGINE TYPE
		



GEARBOX-DIFFERENTIAL

1842133000	Tool for dismantling differential bearing and gearbox gears	●
1842134000	Tool for dismantling gears and gearbox hubs	●
1845028000	Tool for removing differential bearings	●
1845057000	Tool for removing layshaft 5 th speed gear bush	●
1847017001	Tool (to be used with 1860889000)	●
1847056000	Tool for extracting differential output shafts	●
1850113000	Spanner (12 mm) for gearbox oil drain plug	●
1855035000	Spanner (19 mm) for removing and refitting gearbox	●
1860691000	Drift for removing and refitting gear hardening ball plug	●
1860851000	Crossmember for removing-refitting gearbox	●
1860851001	Crossmember adaptor for removing-refitting gearbox (to be used with 1860851000)	●
1860873000	Bracket for removing-refitting gearbox	●
1860889000	Two-way connector for tool (to be used with 1847017001)	●
1861000000	Rotating stand for overhauling engine (also used for gearboxes and differentials)	●
1870007000	Grip for drifts and fitting tools	●
1870152000	Drift for fitting hubs and gears on main and layshafts	●
1870419000	Tool for fitting main shaft gasket on bell housing (to be used with 1870007000)	●

00.A

Tool number	NAME OF TOOL	ENGINE TYPE
		

1870469000	Tool for fitting differential bearing (to be used with 1870007000)	●
1870629000	Drift for fitting differential housing cover gasket (to be used with 1870007000)	●
1870630000	Drift for fitting differential housing gasket (to be used with 1870007000)	●
1870631000	Drift for fitting main and layshaft bearings and gears	●
1870632000	Drift for fitting bearings	●
1870633000	Drift for fitting clutch release control shaft bush	●
1871000000	Rotating stand for overhauling gearboxes and differentials	●
1871001014	Support for gearbox-differential unit whilst overhauling (to be fitted to 1861000000 or 1871000000)	●
1874140001	Pliers for staking nuts	●
1874140005	Pair of tools for staking gearbox shaft nuts (to be used with 1874140001)	●
1875088000	Drift for fitting main and layshaft bearings	●
1881124000	Pliers for adjusting main and layshaft rear bearing circlips	●
1895655000	Tool for determining thickness of differential bearing adjustment shims (to be used with 1895884000)	●
1895884000	Dial gauge (measuring capacity 5 mm; shank length 16.5 mm)	●



DESCRIPTION	Thread	Tightening torques	ENGINE TYPE		
		daNm	 16v	 JTD	 JTD

ENGINE



Bearing cap fixing, flanged bolt	M10	2+90°	●		
	M12	2+100°		●	●
Shield (dust cover) fixing, bolt	M6	0.9		●	●
Sump oil drain plug	M18	2		●	●
Oil sump fixing, bolt	M6	1	●		
		0.1		●	●
	M8	2.5		●	●
Flywheel side and timing side cover fixing, bolt	M6	0.9		●	●
		1	●		
Timing cover shields fixing, bolt	M8	2.2	●		
	M6	0.9	●	●	●
Cylinder head to cylinder block fixing, bolt	M9	4+90°			
	M10	6.5+90°+			
	M12	90°+90°			
Engine support to cylinder block/crankcase fixing, bolt	M8	2.2	●		
	M10	5		●	●
Camshaft cap fixing, nut and bolt	M6	1		●	
	M7	1.5		●	●
Tappet cover to cylinder head fixing, bolt	M6	1		●	●
Inlet manifold to cylinder head fixing, nut	M7	1.5	●		
	M8	2.5		●	●
Exhaust manifold to cylinder head fixing, nut	M8	2.5		●	●
		2.7	●		
Connecting rod caps fixing, bolt	M8	4.1	●		
		2 + 60°		●	●
Engine flywheel fixing, bolt	M8	4.4	●		
	M12	16		●	●
Crankshaft gear fixing bolt (*)	M12	2+90°	●		
	M16	34		●	●
Auxiliary pulley to crankshaft gear fixing, bolt	M8	2.5		●	●
Gear on camshaft (inlet and/or exhaust) fixing, bolt	M12	12	●	●	●

(*) The bolt should not be lubricated

00.

DESCRIPTION	Thread	Tightening torque daNm	ENGINE TYPE		
			 16v	 JTD	 JTD
Sensors to cylinder block/crankcase and cylinder head fixing, flanged bolt	M6	0.9		●	●
Oil pump to crankcase fixing, bolt	M6	0.9		●	
		1			●
Oil dipstick fixing, nut and bolt	M6	0.9			●
Water pump fixing, nut and bolt	M6	1	●		
	M8	2.5		●	●
Thermostat to cylinder head fixing, bolt	M8	2.5		●	
Lower bracket to alternator mounting and alternator fixing, bolt	M10	5		●	●
	M12	7		●	●
Compressor fixing, bolt	M8	2.2	●		
	M10	5	● (*)	●	●
Auxiliary units fixed belt tensioner fixing, nut and bolt	M8	2.5	●	●	●
Power assisted steering pump fixing, bolt	M8	2.5		●	●
Pulley to power assisted steering pump fixing, bolt	M8	2.5		●	●
Water temperature sender unit fixed to cylinder head	M16 tapered	2.5		●	
		3			●
		3.4	●		
Water temperature sender unit	M12	1.2	●		
		2			●
		3		●	
Connecting rod mounting bracket fixing, bolt	M10	5		●	
Alternator strut fixing, bolt	M8	2.5		●	
Driveshaft support fixing, bolt	M10	5		●	●
Oil level sender unit	M12	3			●
Oil pressure switch on cylinder block/crankcase	M14	3		●	●
		3.2	●		

* Value for versions with air conditioning

DESCRIPTION	Thread	Tightening torques daNm	ENGINE TYPE		
			 16v	 JTD	 JTD
Automatic belt tensioner to alternator mounting fixing, bolt	M8	3.2			●
	M10	6			●
Fixed belt tensioner to air conditioning compressor mounting fixing, bolt	M10	5		●	●
Intake to cap fixing, bolt	M6	0.9			●
Sump to driveshaft support fixing, nut for bolt	M8	2.5			●
Power assisted steering pump to connecting rod support fixing, bolt	M8	2.5			●
Oil vapour separator to inlet manifold fixing, nut	M6	0.9		●	●
Auxiliary support to cylinder block/crankcase fixing, flanged bolt	M8	2.5		●	
	M10	5		●	●
Ring nut fixing injectors	M35	12		●	●
Exhaust manifold to cylinder block/crankcase reaction bracket fixing	M8	2.5		●	●
Injection pump to mounting, cylinder block/crankcase and inlet manifold fixing, bolt	M8	2.5		●	●
Reaction bracket to injection pump fixing, nut	M8	2.5		●	●
Injection pump gear fixing, nut and bolt	M14	5		●	●
Complete injector	M24	6		●	●
Fuel filter to inlet manifold fixing, nut	M8	2.5			●
Turbocharger to exhaust manifold fixing, nut	M8	2.5		●	●
Exhaust manifold connector to turbocharger fixing, nut	M8	2.5			●
Filler for oil supply pipe to turbocharger	M12	1.5		●	●



Technical data



Marea- Marea Weekend

Tightening torques

99 range

00.

DESCRIPTION	Thread	Tightening torques daNm	ENGINE TYPE		
			 16v	 JTD	 JTD
Thermostatic valve fixing connector	M20	6		●	●
Complete jet to cylinder block/crankcase fixing, bolt	M6	0.9		●	●
Water outlet front filler to cylinder head fixing, bolt	M6	0.9			●
	M8	2.5			●
Thermostat to water outlet filler from cylinder head fixing, bolt	M7	1.5			●
Alternator upper and lower reaction brackets fixing, bolt	M10	5			●
Vacuum unit to cylinder head fixing, bolt	M8	2.5		●	●
EGR valve to exhaust manifold fixing, nut	M8	2.5		●	●
Pipe to EGR valve fixing, bolt	M8	2.5		●	●
Pipe to exhaust or inlet manifold fixing, nut	M6	0.9			●
Air pressure switch	M12	2			●
Heater plugs	M12	1.5		●	●
Reaction bracket to exhaust manifold fixing, bracket	M8	2.5			●
Lytens automatic tensioner fixing, nut	M8	2.5		●	
Oil filter	M20	1.5		●	●
Fuel supply pipe to the injection pump fixing, nut	M12	2.5		●	
Rigid pipe to turbocharger for draining oil fixing, bolt	M8	2.5		●	
Bracket to crankcase for fixing exhaust manifold reaction bracket fixing, bolt	M8	2.5		●	
	M10	5		●	

DESCRIPTION	Thread	Tightening torques	ENGINE TYPE		
		daNm	 16v	 JTD	 JTD
EGR pipe to exhaust manifold fixing, ring nut	M22	5		●	
Earth lead fixing, bolt	M8	2.2	●		
		2.5		●	
Electrical connections for spark plugs fixing, nut	M4	0.3		●	●
Heat shield to exhaust manifold fixing, TE bolt	M6	0.9	●	●	
Rigid pipe to crankshaft for draining turbo-charger oil fixing, bolt	M8	2.5		●	
Air conditioning to support fixing, bolt	M8	2.5		●	
Rigid pipe to power assisted steering pump fixing, ring nut	M16	3.5		●	
Power assisted steering pipe to pump fixing, bolt	M8	2.5		●	
Spark plugs	M12	2.7	●		
Cap plate fixing, bolt	M7	1.5	●		
Water inlet pipe to crankcase fixing, bolt	M6	1	●		
Camshaft housing fixing, bolt	M8	1.5	●		
Plate to oil pump casing fixing, bolt	M6	0.7	●		
Camshaft housing fixing bolt sealing plug	M16	1.5	●		
Pulley fixing bolt (flywheel)	M8	2.2	●		
Mounting to engine support fixing, nut	M10	6	●		
Oil temperature switch	M16 tapered	3.4	●		



Technical data

Marea- Marea Weekend

Tightening torques



99 range

00

DESCRIPTION	Thread	Tightening torques daNm	ENGINE TYPE		
			 16v	 JTD	 JTD
Connector on inlet duct for vacuum intake	M14 tapered	3.4	●		
Inlet manifold fixing, bolt	M6	0.7	●		
Valve gear timing stud sealing plugs	M6	1.5	●		
Rear cover coil support fixing, nut	M6	0.9	●		
Coils to cover fixing, bolt	M4	0.2	●		
Tapered plug on camshaft housing, rear side	M14 tapered	1.5	●		
Tapered plug on camshaft housing, front side	M20 tapered	4	●		
Plug in camshaft housing fixing manifold	M18	3	●		
Butterfly casing fixing, bolt	M6	0.7	●		
Sensor to oil pump fixing, bolt	M6	1	●		
Recharging cable to alternator fixing, nut	M8	2.5	●		
Alternator rear track to bracket fixing, bolt	M10	5	●		
Alternator to slot fixing, bolt (1)	M10	5	●		
Alternator to filter fixing, bolt	M10 (*)	5 (*)	● (*)		
	M12	8	●		
Front and rear brackets and reinforcement bolt fixing, bolt	M10	5	●		
Front bracket, cylinder block/crankcase, centre bracket fixing, bolt	M10	5	●		
Rear bracket fixing, bolt	M10	5			

(1) Also valid for versions with air conditioning

(*) Value for versions with air conditioning only

DESCRIPTION	Thread	Tightening torques daNm	ENGINE TYPE		
			 16v	 JTD	 JTD
Bracket to crankcase fixing, bolt (air conditioning)	M10	5	●		
Compressor tensioner fixing, bolt	M10	5	●		
Compressor fulcrum fixing, nut	M10	5	●		
Power assisted steering plate fixing, bolt	M8	2.2	●		
	M10	5	●		
Power assisted steering support to crankcase fixing, bolt	M10	5	●		
Compressor/alternator rear support to crankcase fixing, nut and bolt	M10	5	●		
Alternator fixing, bolt	M10	5	●		
	M12	8	●		
Tensioner/alternator fixing, bolt	M8	2.2	●		
Plate to crankcase fixing, bolt	M10	5	●		
Engine support to cylinder block/crankcase fixing, nut	M8	2.5	●		
	M10	6	●		

